

2003-11

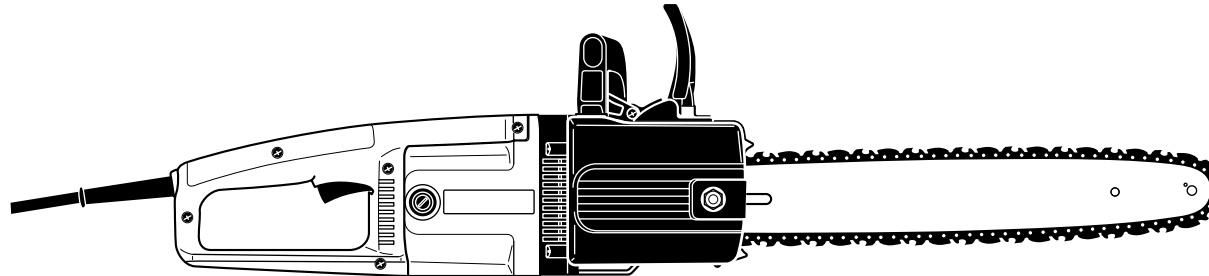

UC3000
UC3500
UC4000

UC3001A
UC3501A
UC4001A

UC3003A
UC3503A
UC4003A
UC4503A

UC3000, 3500, 4000
UC3001A, 3501A, 4001A
UC3003A, 3503A
UC4003A, 4503A

1

Handgriffe, Motorgehäuse, Getriebe
Handles, motor case, gear
Poignées, carter moteur, engrenage
Mangos, carter motor, engranaje

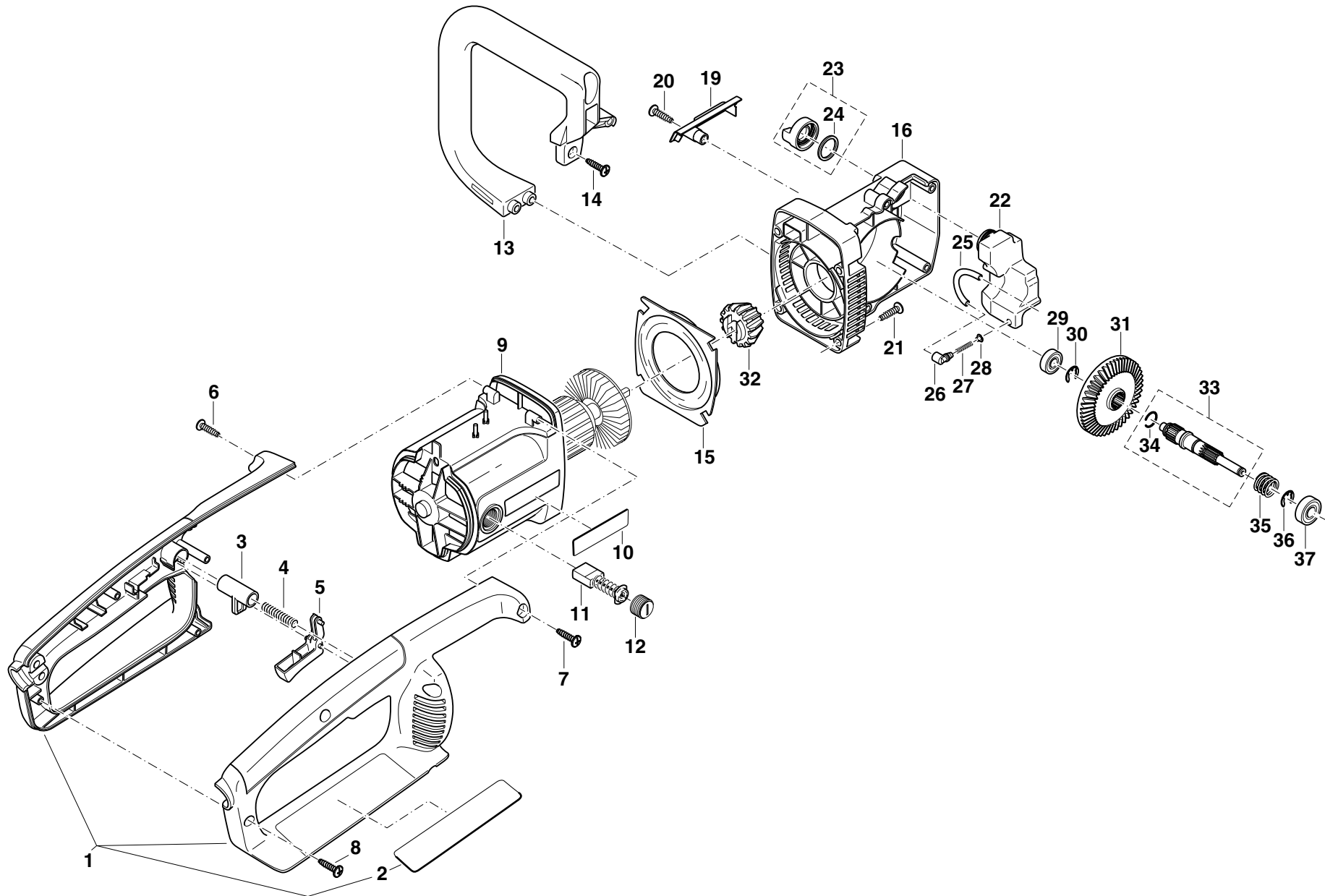

**UC 3000, 3500, 4000, 3001A, 3501A,
4001A, 3003A, 3503A, 4003A, 4503A**



Seite / Page	Pos.	UC3000	UC3500	UC4000	UC3001A	UC3501A	UC4001A	UC3003A	UC3503A	UC4003A	UC4503A	Teil-Nr. Part No. No. de pièce No. de pieza	Hinweise Notes Renseign. Nota	Bezeichnung	Spezifikation Specification	Description	Désignation	Denominación
1	1	1	1	1	1	1	1	1	1	1	1	225 310 660		Handgriff kpl.		Handle cpl.	Poignée cpl.	Mango cpl.
1	1	1	1	1								225 310 620	USA, CDN	Handgriff kpl.		Handle cpl.	Poignée cpl.	Mango cpl.
1	2	1	1	1	1	1	1	1	1	1	1	980 114 181		Sicherheitsaufkleber		Label	Plaque	Calcomania
1	2	1	1	1								980 114 400	USA, CDN	Sicherheitsaufkleber		Label	Plaque	Calcomania
1	3	1	1	1	1	1	1	1	1	1	1	225 144 010		Sperrknopf		Locking button	Bouton de blocage	Botón de bloqueo
1	4	1	1	1	1	1	1	1	1	1	1	225 145 010		Feder		Spring	Ressort	Resorte
1	5	1	1	1	1	1	1	1	1	1	1	225 271 010		Ein-, Ausschalter		Power switch	Interrupteur	Interruptor
1	6	1	1	1	1	1	1	1	1	1	1	913 540 185		Schraube	4x18	Screw	Vis	Tornillo
1	7	1	1	1	1	1	1	1	1	1	1	913 540 185		Schraube	4x18	Screw	Vis	Tornillo
1	8	4	4	4	4	4	4	4	4	4	4	913 540 185		Schraube	4x18	Screw	Vis	Tornillo
1	9	1	1	1	1	1	1	1	1	1	1	225 111 660		Motorgehäuse		Motor case	Carter moteur	Carter motor
1	10	1	1	1	1	1	1	1	1	1	1	980 114 348		Schild		Label	Plaque	Calcomania
1	11	2	2	2	2	2	2	2	2	2	2	957 802 410		Kohlebürste (2 Stck.)		Carbon brush (2 pcs.)	Jeu de balais (2 piè.)	Escob. de carb. (2 pzs.)
1	12	2	2	2	2	2	2	2	2	2	2	970 802 420		Deckel für Kohlebürste		Cover f. carbon brush	Couvercle p. jeu de balais	Tapa p. escob. de carb.
1	13	1	1	1	1	1	1	1	1	1	1	225 310 021		Bügelgriff		Tubular handle	Poignée tubulaire	Mango tubular
1	14	2	2	2	2	2	2	2	2	2	2	913 550 255		Schraube	5x25	Screw	Vis	Tornillo
1	15	1	1	1	1	1	1	1	1	1	1	225 118 010		Luftführung		Air guide plate	Guide d' air	Conducto de aire
1	16	1	1	1	1	1	1	1	1	1	1	225 211 022		Getriebegehäuse links, schwarz		Gear housing left, black	Carter d' engrenage gauche, noir	Cárter de engranaje izqu., negro
1	16	1	1	1								225 211 310	USA, CDN	Getriebegehäuse links kpl., schwarz		Gear housing left cpl., black	Carter d' engrenage gauche, noir	Cárter de engranaje izqu., negro
1	16		1	1								225 211 360	J	Getriebegehäuse links kpl., schwarz		Gear housing left cpl., black	Carter d' engrenage gauche, noir	Cárter de engranaje izqu., negro
1	19	1	1	1	1	1	1	1	1	1	1	225 212 012		Getriebedeckel, schwarz		Cover, black	Couvercle, noir	Tapa, negro
1	20	1	1	1	1	1	1	1	1	1	1	913 540 185		Schraube	4x18	Screw	Vis	Tornillo
1	21	4	4	4	4	4	4	4	4	4	4	913 550 255		Schraube	5x25	Screw	Vis	Tornillo
1	22	1	1	1	1	1	1	1	1	1	1	225 244 010		Öltank		Oil tank	Réservoir d' huile	Depósito de aceite
1	23	1	1	1	1	1	1	1	1	1	1	205 114 202		Tankverschluß kpl.		Tank plug cpl.	Bouchon réservoir cpl.	Cierre depósito cpl.
1	24	1	1	1	1	1	1	1	1	1	1	963 100 081		Dichtung, rot		Gasket, red	Joint, rouge	Junta, rojo
1	25	m	m	m	m	m	m	m	m	m	m	965 452 380		Schlauch		Tube	Gaine	Tubo
1	25	1	1	1	1	1	1	1	1	1	1	965 452 387		Schlauch	L = 93 mm	Tube	Gaine	Tubo
1	26	1	1	1	1	1	1	1	1	1	1	225 243 011		Tankanschlußstück		Connection for tank	Connexion pour réservoir	Conexión p. depósito
1	27	1	1	1	1	1	1	1	1	1	1	225 245 060		Druckfeder		Pressure spring	Ressort de pression	Resorte de presión
1	28	1	1	1	1	1	1	1	1	1	1	021 245 100		Stopfen		Plug	Bouchon	Tapón
1	29	1	1	1	1	1	1	1	1	1	1	960 101 084		Kugellager	608 2Z	Ball bearing	Roulement à billes	Rodamiento de bolas
1	30	1	1	1	1	1	1	1	1	1	1	930 110 120		Sicherungsscheibe		Safety washer	Rondelle de sécurité	Arandela seguridad
1	31	1	1	1	1	1	1	1	1	1	1	225 221 011		Zahnrad kpl.	Z=43	Gear wheel cpl.	Roue dentée	Piñon
1	32	1	1	1	1	1	1	1	1	1	1	225 222 010		Ritzel	Z=14	Pinion	Pignon	Piñon
1	33	1	1	1	1	1	1	1	1	1	1	225 221 030		Welle kpl.		Shaft	Arbre	Eje
1	34	1	1	1	1	1	1	1	1	1	1	930 912 101		Sprengring		Spring ring	Anneau-ressort	Anillo elastico
1	35	1	1	1	1	1	1	1	1	1	1	021 245 040		Antriebsschnecke		Worm	Vis sans fin	Tornillo sin fin
1	36	1	1	1	1	1	1	1	1	1	1	930 110 120		Sicherungsscheibe		Safety washer	Rondelle de sécurité	Arandela seguridad
1	37	1	1	1	1	1	1	1	1	1	1	960 102 124		Kugellager	6201 2Z	Ball bearing	Roulement à billes	Rodamiento de bolas

UC3000, 3500, 4000
UC3001A, 3501A, 4001A
UC3003A, 3503A
UC4003A, 4503A

2

Ölpumpe, Kupplung, Kettenbremse
Oil pump, clutch, chain brake
Pompe a huile, embrayage, frein de chaîne
Bomba de aceite, embrague, freno de cadena

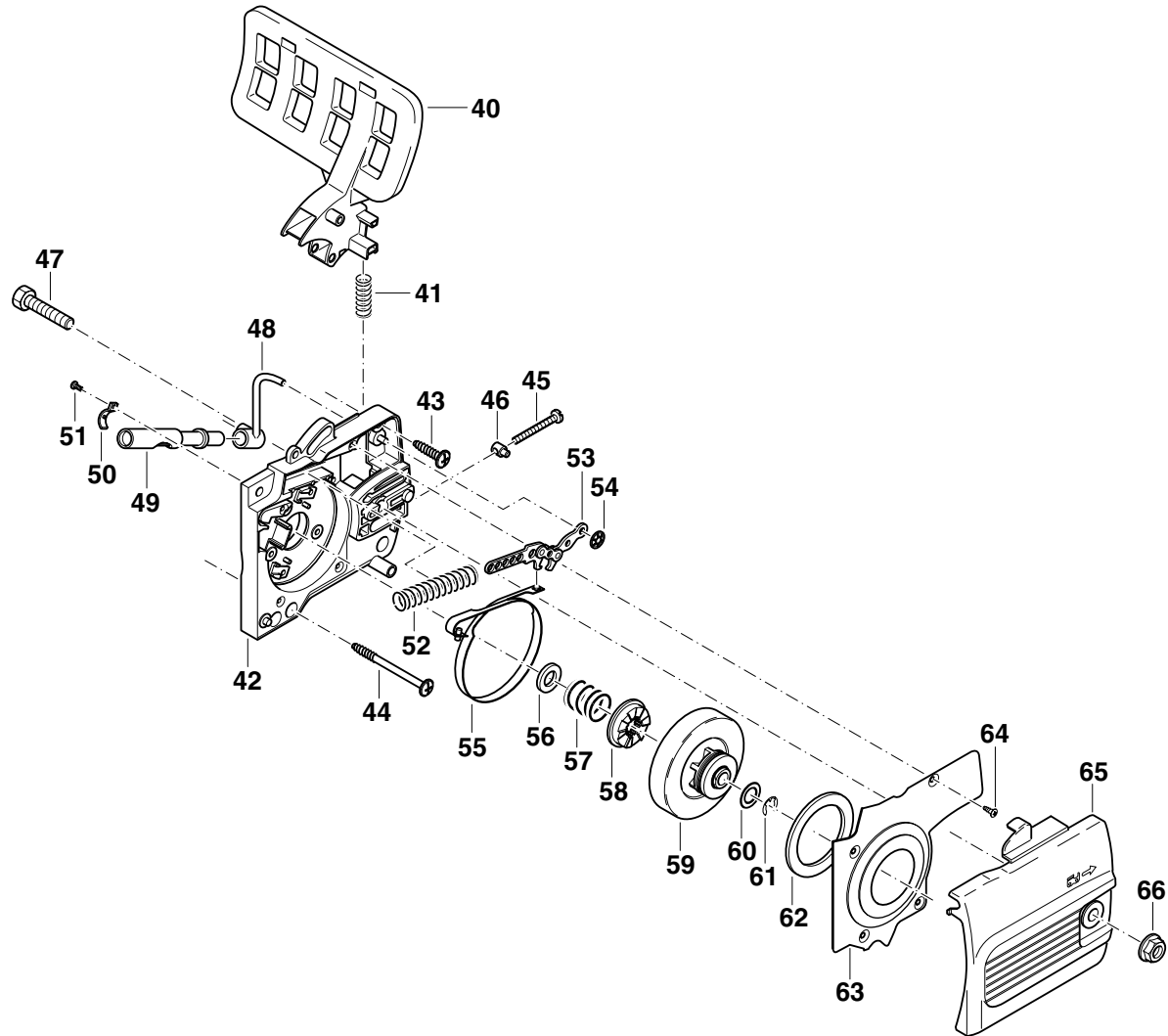

UC 3000, 3500, 4000, 3001A, 3501A,
4001A, 3003A, 3503A, 4003A, 4503A



Seite / Page	Pos.	UC3000	UC3500	UC4000	UC3001A	UC3501A	UC4001A	UC3003A	UC3503A	UC4003A	UC4503A	Teil-Nr. Part No. No. de pièce No. de pieza	Hinweise Notes Renseign. Nota	Bezeichnung	Spezifikation Specification	Description	Désignation	Denominación
2	40	1	1	1	1	1	1	1	1	1	1	225 213 110		Handschutz kpl.		Hand guard cpl.	Protège-main cpl.	Protector de mano cpl.
2	41	1	1	1	1	1	1	1	1	1	1	225 213 060		Feder für Handschutz		Spring for hand guard	Ressort pour protège-main	Muelle p. prot. de mano
2	42	1	1	1	1	1	1	1	1	1	1	225 211 015		Getriebegehäuse rechts		Gear housing right	Carter d'engrenage droit	Cárter de engranaje der.
2	43	2	2	2	2	2	2	2	2	2	2	913 550 255		Schraube	5x25	Screw	Vis	Tornillo
2	44	2	2	2	2	2	2	2	2	2	2	913 550 555		Schraube	5x55	Screw	Vis	Tornillo
2	45	1	1	1	1	1	1	1	1	1	1	901 505 354		Schraube	M5x35	Screw	Vis	Tornillo
2	46	1	1	1	1	1	1	1	1	1	1	001 213 042		Mutter mit Zapfen		Nut with pivot	Ecrou avec pivot	Tuerca con espiga
2	47	1	1	1	1	1	1	1	1	1	1	900 208 304		6kt-Schraube	M8x30	Hexagonal screw	Vis hexagonal	Tornillo hexagonal
2	48	1	1	1	1	1	1	1	1	1	1	225 242 010		Druckleitung		Tube	Gaine	Tubo
2	49	1	1	1	1	1	1	1	1	1	1	021 245 003		Ölpumpe kpl.		Oil pump cpl.	Pompe à huile cpl.	Bomba de aceite cpl.
2	50	1	1	1	1	1	1	1	1	1	1	203 245 001		Halter für Ölpumpe		Holder for oil pump	Crampon p. pompe à huile	Empuñadura p. bomba
2	51	1	1	1	1	1	1	1	1	1	1	915 135 100		Schraube	3,5x9,5	Screw	Vis	Tornillo
2	52	1	1	1	1	1	1	1	1	1	1	028 213 521		Speicherfeder		Spring	Ressort	Resorte
2	53	1	1	1	1	1	1	1	1	1	1	028 213 532		Bremsbandhalter kpl.		Brake spring holder cpl.	Support de ressort de frein cpl.	Soporte de cinta de freno cpl.
2	54	1	1	1	1	1	1	1	1	1	1	930 304 030		Klemmscheibe		Clamp washer	Rondelle de serrage	Conexión de borne
2	55	1	1	1	1	1	1	1	1	1	1	225 213 050		Bremsband		Brake spring	Ressort de frein	Cinta de freno
2	56	1	1	1	1	1	1	1	1	1	1	225 189 010		Scheibe	ø 12/16x4	Washer	Rondelle	Arandela
2	57	1	1	1	1	1	1	1	1	1	1	225 184 012		Druckfeder für Klauenkupplung		Pressure spring	Ressort de pression	Resorte de presión
2	58	1	1	1	1	1	1	1	1	1	1	225 229 010		Klauenkupplung		Clawcoupling	Embrayage à griffes	Embrague de garras
2	59	1	1	1	1	1	1	1	1	1	1	225 223 110		Kupplungstrommel kpl.	3/8"	Clutch drum cpl.	Tambour cpl.	Tambor cpl.
2	60	1	1	1	1	1	1	1	1	1	1	221 229 180		Scheibe	ø 8/14x0,5	Washer	Rondelle	Arandela
2	61	1	1	1	1	1	1	1	1	1	1	930 106 070		Sicherungsscheibe		Safety washer	Rondelle de sécurité	Arandela seguridad
2	62	1	1	1	1	1	1	1	1	1	1	965 527 070		Dichtung		Gasket	Joint	Junta
2	63	1	1	1	1	1	1	1	1	1	1	225 282 011		Abdeckblech		Cover plate	Tôle de recouvrement	Chapa protectora
2	64	4	4	4	4	4	4	4	4	4	4	915 835 100		Schraube	3,5x9,5	Screw	Vis	Tornillo
2	65	1	1	1	1	1	1	1	1	1	1	225 213 102		Kettenradschutz kpl., schwarz		Sprocket guard, black	Protège-pignon, noir	Protector de piñon, negro
2	66	1	1	1	1	1	1	1	1	1	1	923 208 004		6kt-Mutter mit Bund	M8	Hexagonal nut	Ecrou hexagonal	Tuerca hexagonal

UC3001A, 3501A, 4001A
UC3003A, 3503A
UC4003A, 4503A

3

Motor, Kabel, Schalter
Motor, cable, switch
Moteur, câble, interrupteur
Motor, cable, interruptor

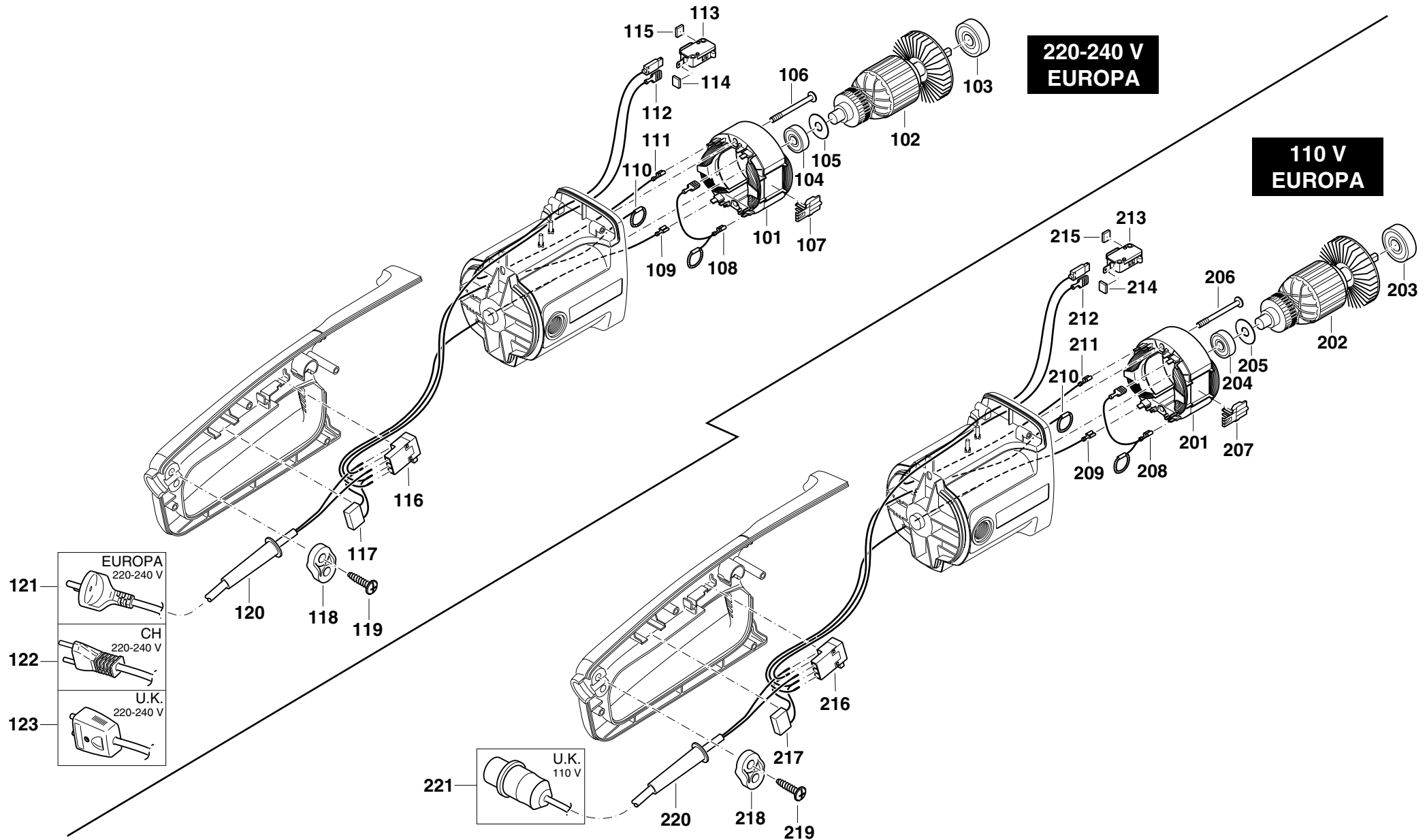

**UC 3000, 3500, 4000, 3001A, 3501A,
4001A, 3003A, 3503A, 4003A, 4503A**



Seite / Page	Pos.	UC3000	UC3500	UC4000	UC3001A	UC3501A	UC4001A	UC3003A	UC3503A	UC4003A	UC4503A	Teil-Nr. Part No. No. de pièce No. de pieza	Hinweise Notes Renseign. Nota	Bezeichnung	Spezifikation Specification	Description	Désignation	Denominación
3	101				1	1	1	1	1	1	1	970 802 270		Stator kpl.	220-240 V	Stator assy.	Stator cpl.	Estator cpl.
3	102				1	1	1	1	1	1	1	970 802 350		Rotor kpl.	220-240 V	Rotor assy.	Rotor cpl.	Rotor cpl.
3	103				1	1	1	1	1	1	1	960 103 126		Kugellager	6301 2RS	Ball bearing	Roulement à billes	Rodamiento de bolas
3	104				1	1	1	1	1	1	1	960 102 094		Kugellager	629 2ZR	Ball bearing	Roulement à billes	Rodamiento de bolas
3	105				1	1	1	1	1	1	1	970 802 610		Distanzbuchse		Distance piece	Pièce intercalaire	Anillo separador
3	106				2	2	2	2	2	2	2	913 550 555		Schraube	5x55	Screw	Vis	Tornillo
3	107				1	1	1	1	1	1	1	970 801 860		Klammer		Clamp	Crampon	Grapa
3	108				1	1	1	1	1	1	1	970 311 530		Kabel, weiß	R13	Cable, white	Câble, blanc	Cable, blanco
3	109				1	1	1	1	1	1	1	970 311 330		Kabel, gelb	R4	Cable, yellow	Câble, jaune	Cable, amarillo
3	110				1	1	1	1	1	1	1	970 311 360		Kabel, orange	R1	Cable, orange	Câble, orange	Cable, naranja
3	111				1	1	1	1	1	1	1	970 311 320		Kabel, schwarz	R3	Cable, black	Câble, noir	Cable, negro
3	112				1	1	1	1	1	1	1	970 311 310		Kabel, schwarz	R2	Cable, black	Câble, noir	Cable, negro
3	113				1	1	1	1	1	1	1	970 001 200		Mikroschalter		Switch	Interrupteur	Interruptor
3	114				1	1	1	1	1	1	1	965 404 430		Dichtung		Gasket	Joint	Junta
3	115				1	1	1	1	1	1	1	965 404 430		Dichtung		Gasket	Joint	Junta
3	116				1	1	1	1	1	1	1	975 001 190		Druckknopfschalter		Push button	Bouton-poussoir	Interruptor pulsador
3	117				1	1	1	1	1	1	1	970 109 810		Kondensator		Capacitor	Condensateur	Condensador
3	118				1	1	1	1	1	1	1	225 152 060		Zugentlastung, rot		Traction relief, red	Collier, rouge	Dispos. contratr., rojo
3	119				2	2	2	2	2	2	2	913 540 185		Schraube	4x18	Screw	Vis	Tornillo
3	120				1	1	1	1	1	1	1	225 152 010		Knickschutz		Break protection	Passe-câble	Boquilla de paso
3	121				1	1	1	1	1	1	1	970 102 110		Kabel mit Stecker	EUROPA	Cable with plug	Câble avec prise	Cable con enchufe
3	122				1	1	1	1	1	1	1	970 102 130		Kabel mit Stecker	CH	Cable with plug	Câble avec prise	Cable con enchufe
3	123				1	1	1	1	1	1	1	970 102 151		Kabel mit Stecker	U.K.	Cable with plug	Câble avec prise	Cable con enchufe
3	201				1	1	1	1	1	1	1	970 802 260		Stator kpl.	110 V	Stator assy.	Stator cpl.	Estator cpl.
3	202				1	1	1	1	1	1	1	970 802 320		Rotor kpl.	110 V	Rotor assy.	Rotor cpl.	Rotor cpl.
3	203				1	1	1	1	1	1	1	960 103 126		Kugellager	6301 2RS	Ball bearing	Roulement à billes	Rodamiento de bolas
3	204				1	1	1	1	1	1	1	960 102 094		Kugellager	629 2ZR	Ball bearing	Roulement à billes	Rodamiento de bolas
3	205				1	1	1	1	1	1	1	970 802 610		Distanzbuchse		Distance piece	Pièce intercalaire	Anillo separador
3	206				2	2	2	2	2	2	2	913 550 555		Schraube	5x55	Screw	Vis	Tornillo
3	207				1	1	1	1	1	1	1	970 801 860		Klammer		Clamp	Crampon	Grapa
3	208				1	1	1	1	1	1	1	970 311 530		Kabel, weiß	R13	Cable, white	Câble, blanc	Cable, blanco
3	209				1	1	1	1	1	1	1	970 311 330		Kabel, gelb	R4	Cable, yellow	Câble, jaune	Cable, amarillo
3	210				1	1	1	1	1	1	1	970 311 360		Kabel, orange	R1	Cable, orange	Câble, orange	Cable, naranja
3	211				1	1	1	1	1	1	1	970 311 320		Kabel, schwarz	R3	Cable, black	Câble, noir	Cable, negro
3	212				1	1	1	1	1	1	1	970 311 310		Kabel, schwarz	R2	Cable, black	Câble, noir	Cable, negro
3	213				1	1	1	1	1	1	1	970 001 200		Mikroschalter		Switch	Interrupteur	Interruptor
3	214				1	1	1	1	1	1	1	965 404 430		Dichtung		Gasket	Joint	Junta
3	215				1	1	1	1	1	1	1	965 404 430		Dichtung		Gasket	Joint	Junta
3	216				1	1	1	1	1	1	1	975 001 190		Druckknopfschalter		Push button	Bouton-poussoir	Interruptor pulsador
3	217				1	1	1	1	1	1	1	970 109 920		Kondensator		Capacitor	Condensateur	Condensador
3	218				1	1	1	1	1	1	1	225 152 150		Zugentlastung, blau		Traction relief, blue	Collier, bleu	Dispos. contratracc., azul
3	219				2	2	2	2	2	2	2	913 540 185		Schraube	4x18	Screw	Vis	Tornillo
3	220				1	1	1	1	1	1	1	225 152 020		Knickschutz		Break protection	Passe-câble	Boquilla de paso
3	221				1	1	1	1	1	1	1	970 102 290		Kabel mit Stecker	U.K.	Cable with plug	Câble avec prise	Cable con enchufe

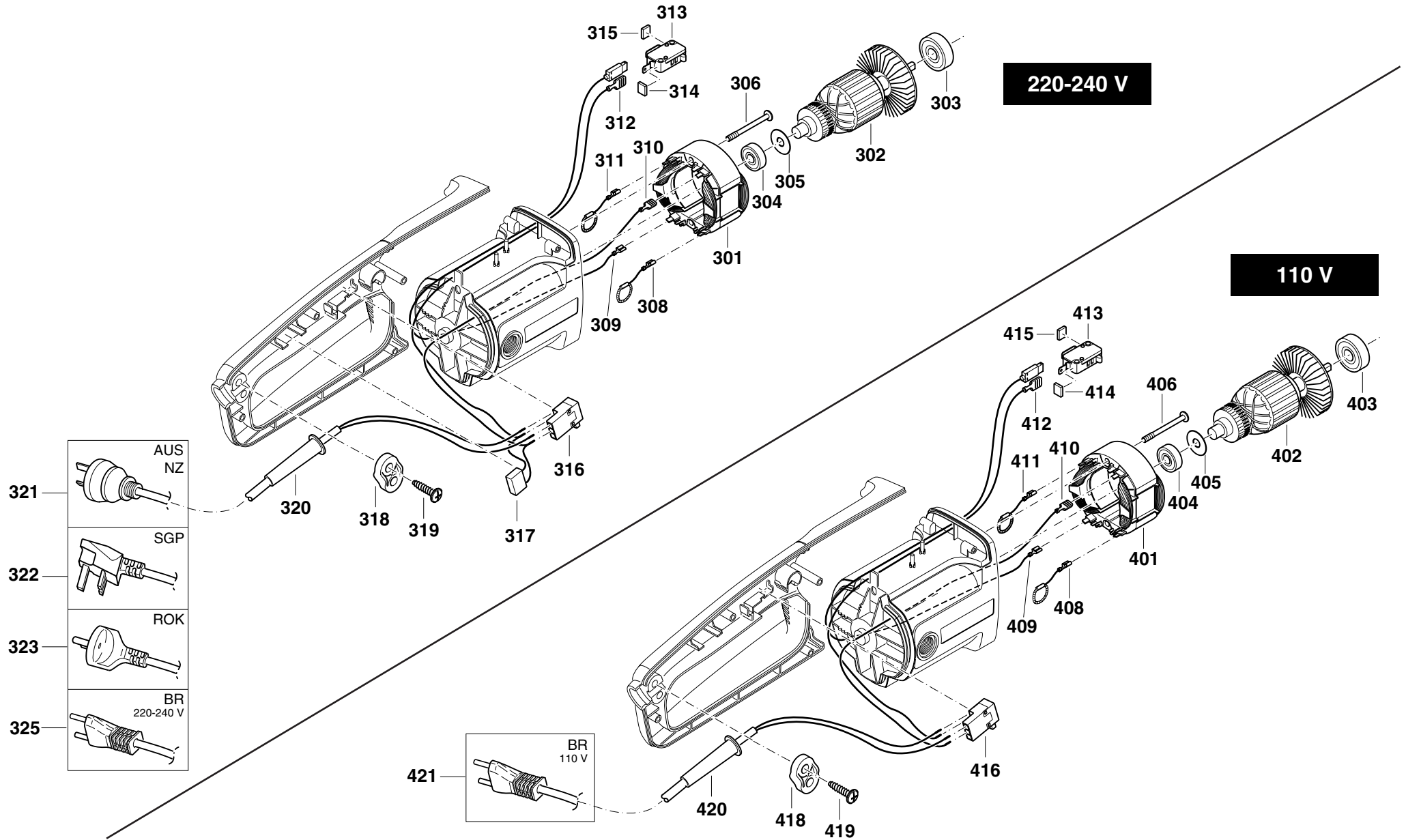

**UC 3000, 3500, 4000, 3001A, 3501A,
4001A, 3003A, 3503A, 4003A, 4503A**



Seite / Page	Pos.	UC3000	UC3500	UC4000	UC3001A	UC3501A	UC4001A	UC3003A	UC3503A	UC4003A	UC4503A	Teil-Nr. Part No. No. de pièce No. de pieza	Hinweise Notes Renseign. Nota	Bezeichnung	Spezifikation Specification	Description	Désignation	Denominación
4	301	1	1	1								970 802 250		Stator kpl.	220-240 V	Stator assy.	Stator cpl.	Estator cpl.
4	302	1	1	1								970 802 330		Rotor kpl.	220-240 V	Rotor assy.	Rotor cpl.	Rotor cpl.
4	303	1	1	1								960 103 126		Kugellager	6301 2RS	Ball bearing	Roulement à billes	Rodamiento de bolas
4	304	1	1	1								960 102 094		Kugellager	629 2ZR	Ball bearing	Roulement à billes	Rodamiento de bolas
4	305	1	1	1								970 802 610		Distanzbuchse		Distance piece	Pièce intercalaire	Anillo separador
4	306	2	2	2								913 550 555		Schraube	M5x55	Screw	Vis	Tornillo
4	308	1	1	1								970 311 380		Kabel, schwarz	R8	Cable, black	Câble, noir	Cable, negro
4	309	1	1	1								970 311 370		Kabel, weiß	R7	Cable, white	Câble, blanc	Cable, blanco
4	310	1	1	1								970 311 330		Kabel, gelb	R4	Cable, yellow	Câble, jaune	Cable, amarillo
4	311	1	1	1								970 311 380		Kabel, schwarz	R8	Cable, black	Câble, noir	Cable, negro
4	312	1	1	1								970 311 310		Kabel, schwarz	R2	Cable, black	Câble, noir	Cable, negro
4	313	1	1	1								970 001 200		Mikroschalter		Switch	Interrupteur	Interruptor
4	314	1	1	1								965 404 430		Dichtung		Gasket	Joint	Junta
4	315	1	1	1								965 404 430		Dichtung		Gasket	Joint	Junta
4	316	1	1	1								975 001 200		Druckknopfschalter		Push button	Bouton-poussoir	Interruptor pulsador
4	317	1	1	1								970 109 810		Kondensator		Capacitor	Condensateur	Condensador
4	318	1	1	1								225 152 150		Zugentlastung, blau		Traction relief, blue	Collier, bleu	Dispos. contratracc., azul
4	319	2	2	2								913 540 185		Schraube	4x18	Screw	Vis	Tornillo
4	320	1	1	1								225 152 010		Knickschutz		Break protection	Passe-câble	Boquilla de paso
4	321	1	1	1								970 102 170		Kabel mit Stecker	AUS, NZ	Cable with plug	Câble avec prise	Cable con enchufe
4	322	1	1	1								970 102 260		Kabel mit Stecker	SGP	Cable with plug	Câble avec prise	Cable con enchufe
4	323	1	1	1								970 102 110		Kabel mit Stecker	ROK	Cable with plug	Câble avec prise	Cable con enchufe
4	325	1	1	1								970 102 400		Kabel mit Stecker	BR	Cable with plug	Câble avec prise	Cable con enchufe
4	401	1	1	1								970 802 220		Stator kpl.	110 V	Stator assy.	Stator cpl.	Estator cpl.
4	402	1	1	1								970 802 320		Rotor kpl.	110 V	Rotor assy.	Rotor cpl.	Rotor cpl.
4	403	1	1	1								960 103 126		Kugellager	6301 2RS	Ball bearing	Roulement à billes	Rodamiento de bolas
4	404	1	1	1								960 102 094		Kugellager	629 2ZR	Ball bearing	Roulement à billes	Rodamiento de bolas
4	405	1	1	1								970 802 610		Distanzbuchse		Distance piece	Pièce intercalaire	Anillo separador
4	406	2	2	2								913 550 555		Schraube	M5x55	Screw	Vis	Tornillo
4	408	1	1	1								970 311 380		Kabel, schwarz	R8	Cable, black	Câble, noir	Cable, negro
4	409	1	1	1								970 311 370		Kabel, weiß	R7	Cable, white	Câble, blanc	Cable, blanco
4	410	1	1	1								970 311 330		Kabel, gelb	R4	Cable, yellow	Câble, jaune	Cable, amarillo
4	411	1	1	1								970 311 380		Kabel, schwarz	R8	Cable, black	Câble, noir	Cable, negro
4	412	1	1	1								970 311 310		Kabel, schwarz	R2	Cable, black	Câble, noir	Cable, negro
4	413	1	1	1								970 001 200		Mikroschalter		Switch	Interrupteur	Interruptor
4	414	1	1	1								965 404 430		Dichtung		Gasket	Joint	Junta
4	415	1	1	1								965 404 430		Dichtung		Gasket	Joint	Junta
4	416	1	1	1								975 001 200		Druckknopfschalter		Push button	Bouton-poussoir	Interruptor pulsador
4	418	1	1	1								225 152 060		Zugentlastung, rot		Traction relief, red	Collier, rouge	Dispos. contratr., rojo
4	418	1	1	1								225 152 150		Zugentlastung, blau		Traction relief, blue	Collier, bleu	Dispos. contratracc., azul
4	419	2	2	2								913 540 185		Schraube	4x18	Screw	Vis	Tornillo
4	420	1	1	1								225 152 010		Knickschutz		Break protection	Passe-câble	Boquilla de paso
4	421	1	1	1								970 102 390		Kabel mit Stecker	BR	Cable with plug	Câble avec prise	Cable con enchufe

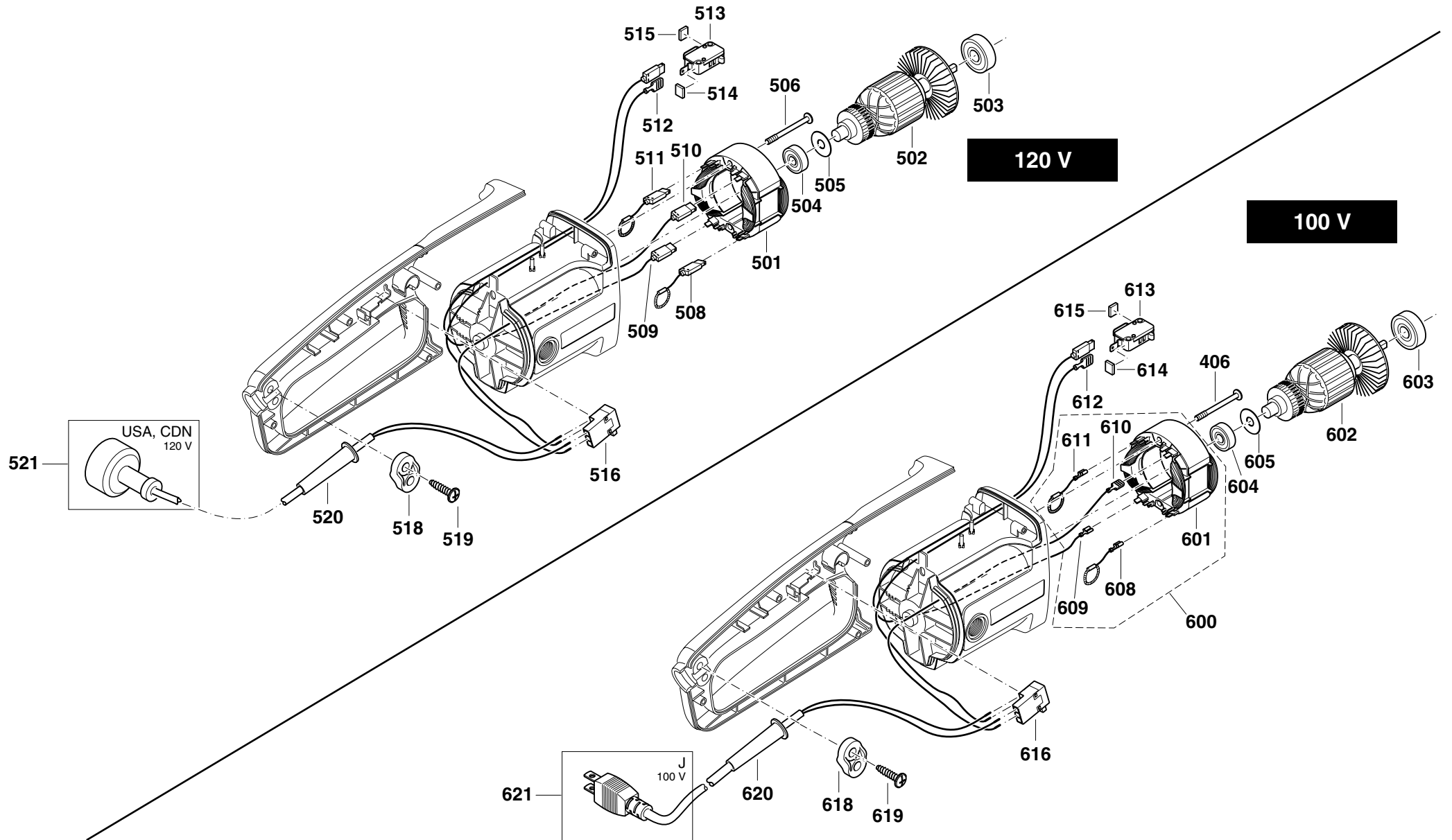

**UC 3000, 3500, 4000, 3001A, 3501A,
4001A, 3003A, 3503A, 4003A, 4503A**



Seite / Page	Pos.	UC3000	UC3500	UC4000	UC3001A	UC3501A	UC4001A	UC3003A	UC3503A	UC4003A	UC4503A	Teil-Nr. Part No. No. de pièce No. de pieza	Hinweise Notes Renseign. Nota	Bezeichnung	Spezifikation Specification	Description	Désignation	Denominación
5	501	1	1	1								970 802 220		Stator kpl.	120 V	Stator assy.	Stator cpl.	Estator cpl.
5	502	1	1	1								970 802 320		Rotor kpl.	120 V	Rotor assy.	Rotor cpl.	Rotor cpl.
5	503	1	1	1								960 103 126		Kugellager	6301 2RS	Ball bearing	Roulement à billes	Rodamiento de bolas
5	504	1	1	1								960 102 094		Kugellager	629 2ZR	Ball bearing	Roulement à billes	Rodamiento de bolas
5	505	1	1	1								970 802 610		Distanzbuchse		Distance piece	Pièce intercalaire	Anillo separador
5	506	2	2	2								913 550 555		Schraube	M5x55	Screw	Vis	Tornillo
5	508	1	1	1								970 311 410		Kabel, schwarz	R11	Cable, black	Câble, noir	Cable, negro
5	509	1	1	1								970 311 400		Kabel, weiß	R10	Cable, white	Câble, blanc	Cable, blanco
5	510	1	1	1								970 311 390		Kabel, gelb	R9	Cable, yellow	Câble, jaune	Cable, amarillo
5	511	1	1	1								970 311 410		Kabel, schwarz	R11	Cable, black	Câble, noir	Cable, negro
5	512	1	1	1								970 311 420		Kabel, orange	R12	Cable, orange	Câble, orange	Cable, naranja
5	513	1	1	1								970 001 200		Mikroschalter		Switch	Interrupteur	Interruptor
5	514	1	1	1								965 404 430		Dichtung		Gasket	Joint	Junta
5	515	1	1	1								965 404 430		Dichtung		Gasket	Joint	Junta
5	516	1	1	1								975 001 200		Druckknopfschalter		Push button	Bouton-poussoir	Interruptor pulsador
5	518	1	1	1								225 152 060		Zugentlastung, rot		Traction relief, red	Collier, rouge	Dispos. contratr., rojo
5	519	2	2	2								913 540 185		Schraube	4x18	Screw	Vis	Tornillo
5	520	1	1	1								225 152 010		Knickschutz		Break protection	Passe-câble	Boquilla de paso
5	521	1	1	1								970 102 221		Kabel mit Stecker	USA, CDN	Cable with plug	Câble avec prise	Cable con enchufe
5	600		1	1								970 802 215		Stator kpl. mit Kabel	100 V	Stator assy. with cable	Stator cpl. avec câble	Estator cpl. con cable
5	601		1	1								970 802 210		Stator kpl.	100 V	Stator assy.	Stator cpl.	Estator cpl.
5	602		1	1								970 802 310		Rotor kpl.	100 V	Rotor assy.	Rotor cpl.	Rotor cpl.
5	603		1	1								960 103 126		Kugellager	6301 2RS	Ball bearing	Roulement à billes	Rodamiento de bolas
5	604		1	1								960 102 094		Kugellager	629 2ZR	Ball bearing	Roulement à billes	Rodamiento de bolas
5	605		1	1								970 802 610		Distanzbuchse		Distance piece	Pièce intercalaire	Anillo separador
5	606		2	2								913 550 555		Schraube	M5x55	Screw	Vis	Tornillo
5	608		1	1								970 311 380		Kabel, schwarz	R8	Cable, black	Câble, noir	Cable, negro
5	609		1	1								970 311 370		Kabel, weiß	R7	Cable, white	Câble, blanc	Cable, blanco
5	610		1	1								970 311 330		Kabel, gelb	R4	Cable, yellow	Câble, jaune	Cable, amarillo
5	611		1	1								970 311 380		Kabel, schwarz	R8	Cable, black	Câble, noir	Cable, negro
5	612		1	1								970 311 310		Kabel, schwarz	R2	Cable, black	Câble, noir	Cable, negro
5	613		1	1								970 001 200		Mikroschalter		Switch	Interrupteur	Interruptor
5	614		1	1								965 404 430		Dichtung		Gasket	Joint	Junta
5	615		1	1								965 404 430		Dichtung		Gasket	Joint	Junta
5	616		1	1								975 001 200		Druckknopfschalter		Push button	Bouton-poussoir	Interruptor pulsador
5	618		1	1								225 152 150		Zugentlastung, blau		Traction relief, blue	Collier, bleu	Dispos. contratracc., azul
5	619		2	2								913 540 185		Schraube	4x18	Screw	Vis	Tornillo
5	620		1	1								225 152 010		Knickschutz		Break protection	Passe-câble	Boquilla de paso
5	621		1	1								970 102 120		Kabel mit Stecker	J	Cable with plug	Câble avec prise	Cable con enchufe

UC3000, 3500, 4000
UC3001A, 3501A, 4001A
UC3003A, 3503A
UC4003A, 4503A

6

Sägeschiene, Sägekette, Werkzeug
Guide bars, saw chains, tools
Guide-chaîne, chaînes, outils
Rieles guía, cadenas sierra, herramientas

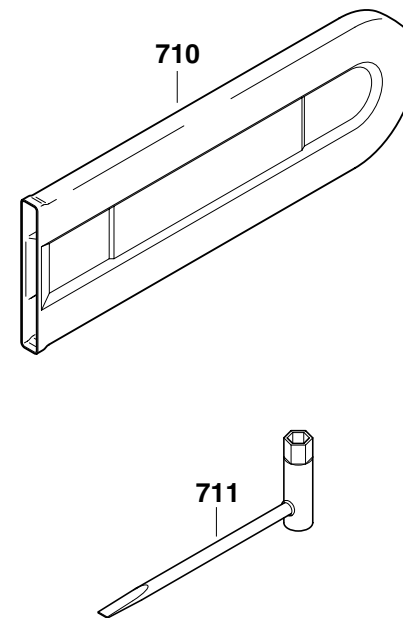
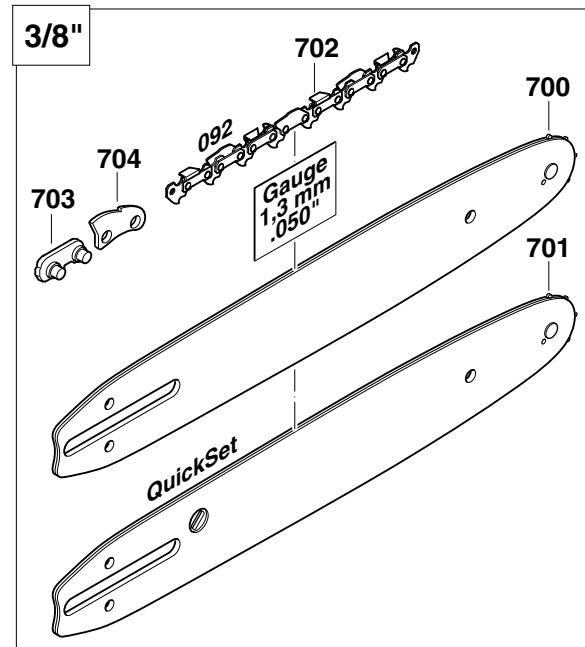

UC 3000, 3500, 4000, 3001A, 3501A,
4001A, 3003A, 3503A, 4003A, 4503A



Seite / Page	Pos.	UC3000	UC3500	UC4000	UC3001A	UC3501A	UC4001A	UC3003A	UC3503A	UC4003A	UC4503A	Teil-Nr. Part No. No. de pièce No. de pieza	Hinweise Notes Renseign. Nota	Bezeichnung	Spezifikation Specification	Description	Désignation	Denominación
6	700	1			1							442 030 661		Sternschiene	3/8" .050" 30cm-12"	Sprocket nose bar	Guide à étoile	Barra guía
6	700		1			1						442 035 661		Sternschiene	3/8" .050" 35cm-14"	Sprocket nose bar	Guide à étoile	Barra guía
6	700			1			1					442 040 661		Sternschiene	3/8" .050" 40cm-16"	Sprocket nose bar	Guide à étoile	Barra guía
6	700									1		442 045 661		Sternschiene	3/8" .050" 45cm-18"	Sprocket nose bar	Guide à étoile	Barra guía
6	701	=			=			=				442 035 061	Acc.	Sternschiene QuickSet	3/8" .050" 35cm-14"	Sprocket nose bar	Guide à étoile	Barra guía
6	701		=			=			=			442 040 061	Acc.	Sternschiene QuickSet	3/8" .050" 40cm-16"	Sprocket nose bar	Guide à étoile	Barra guía
6	702	1			1			1				528 092 646		Sägekette	3/8" .050" 30cm-12"	Saw chain	Chaîne	Cadena
6	702		1			1			1			528 092 652		Sägekette	3/8" .050" 35cm-14"	Saw chain	Chaîne	Cadena
6	702			1			1			1		528 092 656		Sägekette	3/8" .050" 40cm-16"	Saw chain	Chaîne	Cadena
6	702										1	528 092 662		Sägekette	3/8" .050" 45cm-18"	Saw chain	Chaîne	Cadena
6	702		1									528 091 052	USA, CDN, J	Sägekette	3/8" .050" 35cm-14"	Saw chain	Chaîne	Cadena
6	702			1								528 091 056	USA, CDN, J	Sägekette	3/8" .050" 40cm-16"	Saw chain	Chaîne	Cadena
6	703	1	1	1	1	1	1	1	1	1	1	558 092 010		Außenlasche mit Niet	3/8" .050"	Tie strap with rivets	Eclisse extérieure a. rivets	Tira exter. con remache
6	704	1	1	1	1	1	1	1	1	1	1	558 092 000		Sicherheitslasche	3/8" .050"	Safety tie strap	Eclisse de sécurité	Tira seguridad
6	710	1	1	1	1	1	1	1	1	1		952 100 633		Sägekettenschutz		Chain protection cover	Enveloppe protectrice	Estuche protector
6	710										1	952 100 653		Sägekettenschutz		Chain protection cover	Enveloppe protectrice	Estuche protector
6	711	1	1	1	1	1	1	1	1	1	1	941 713 001		Kombischlüssel	SW 13	Universal wrench	Clé combinée	Llave de bujía

UC3000, 3500, 4000
UC3001A, 3501A, 4001A
UC3003A, 3503A
UC4003A, 4503A

Inhaltsverzeichnis
Index
Table des matières
Indice



1	Handgriffe, Motorgehäuse, Getriebe	Handles, motor case, gear	Poignées, carter moteur, engrenage	Mangos, carter motor, engranaje
2	Ölpumpe, Kupplung, Kettenbremse	Oil pump, clutch, chain brake	Pompe a huile, embrayage, frein de chaîne	Bomba de aceite, embrague, freno de cadena
3 - 5	Motor, Kabel, Schalter	Motor, cable, switch	Moteur, câble, interrupteur	Motor, cable, interruptor
6	Sägeschienen, Sägeketten, Werkzeug	Guide bars, saw chains, tools	Guide-chaîne, chaînes, outils	Rieles guía, cadenas sierra, herramientas

	Zeichenerklärung (D)	Key to symbols (GB)	Légende (F)	Explicación de símbolos (E)
<p>⇒ 1999999 2000000 ⇒ 4/95 ⇒ SI 5/95 Acc. = { m Corr.</p>	<p>Produktion bis Serien-Nr. Neues Teil ab Serien-Nr. Neues Teil ab Monat / Jahr Siehe Technische Information Jahr / Nr. Zubehör (nicht im Lieferumfang) Keine Serienausführung, jedoch verwendbar Beinhaltet Positions-Nr. Meterware Druckfehlerberichtigung</p>	<p>Production to serial number New part from serial number New part from Month / Year See Technical Information Year / No. Accessories (not included in the delivery inventory) No standard execution, may be used Contains item number Sold by the meter Error correction</p>	<p>Production jusqu'à n° de série Nouveau pièce à partir du n° de série Nouveau pièce à partir de mois / année Voir information technique année / n° Accessoires (non compris dans la livraison) Aucune exécut. en série, cependant utilisable contient n° de numéro Au mètre Rectification d'erreurs</p>	<p>Producción hasta N° de serie Pieza nueva a partir de N° de serie Pieza nueva a partir de mes / año Véase inform. técnico año / N° Accesorios (no incluido en la extensión del suministro) No es de serie, pero sirve Contiene pos N° Por metro Fe de erratas</p>
	Verklaring der tekens (NL)	Chiarificazione dei simboli (I)	Objasnitev znakov (SLO)	Επεξήγηση συμβόλων (GR)
<p>⇒ 1999999 2000000 ⇒ 4/95 ⇒ SI 5/95 Acc. = { m Corr.</p>	<p>In productie tot serie-Nr. Nieuw onderdeel vanaf serie-Nr. Nieuw onderdeel vanaf maand / jaar Zie technische informatie jaar / Nr. Accessoires (niet meegeleverd) Geen serieuitvoering, maar wel bruikbaar Omvat Positie-Nr. Metergoed Drukfoutcorrectie</p>	<p>Produzione fino al n. di serie Nuovo pezzo a partire dal n. di serie Nuovo pezzo a partire dal mese / anno Vedere il inform. tecnici del anno / n. Accessori (non compresi nell'insieme di fornitura) Non è un modello di serie, ma ugualm. utilizza. Comprende la posizione n. Articoli a metraggio Rettifica di errori di stampa</p>	<p>Produkcija do serijske številke Novi del od serijske številke Novi del od meseca / leta dalje Glej tehnične informacije od leta / številke Pritikline (niso v obsegu dostave) Ni serijska izvedba, a uporabno Vsebuje pozicijsko število Metrsko blago Popravek tiskovnih napak</p>	<p>Παραγωγή μέχρι τον αριθμό σειράς Νέο εξάρτημα από τον αριθμό σειράς Νέο εξάρτημα από το μήνα / έτος Βλέπε πληροφορίες του τεχνικά το έτος / αριθμό Πρόσθετα εξαρτήματα (δεν ανήκουν στη συσκευασία παράδοσης) Δεν έχει εκδοθεί σε σειρά, αλλά χρησιμοποιείται Περιλαμβάνει τον αριθμό θέσης Εμπόρευμα με το μέτρο Διόρθωση λάθους πίεσης</p>