

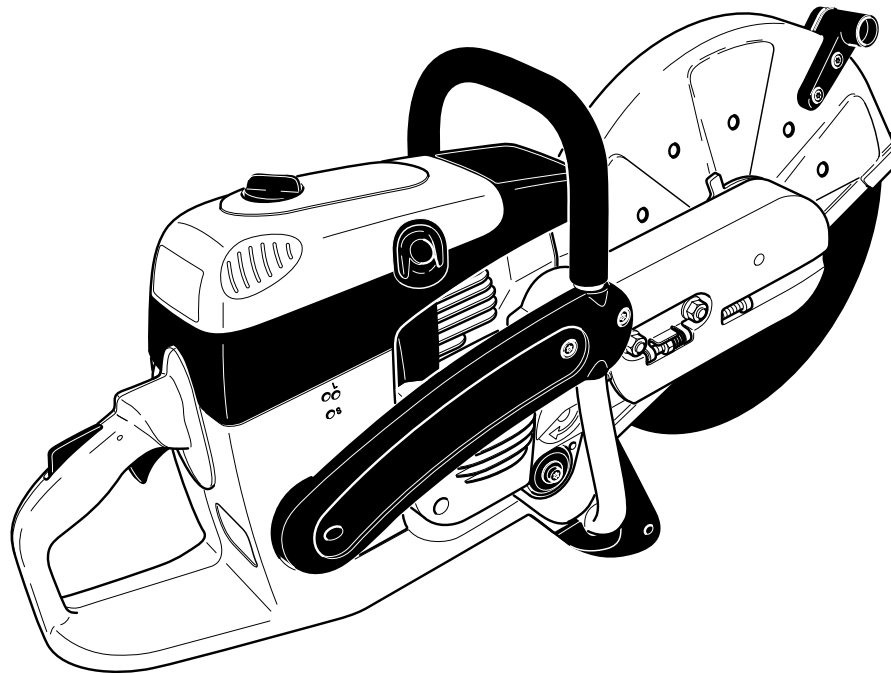

Spare Parts List
Ersatzteilliste
Liste de pièces détachées
Lista de piezas de repuesto

2012-01



- DPC6430
- DPC6431
- DPC7330
- DPC7331
- DPC8131
- DPC8132
- DPC6440
- DPC6441
- DPC7340
- DPC7341
- DPC6430 (UK)
- DPC7331 (UK)
- DPC8131 (UK)
- DPC8132 (UK)
- DPC6440 (UK)
- DPC7341 (UK)
- DPC6430 (USA)
- DPC6431 (USA)
- DPC7330 (USA)
- DPC7331 (USA)
- DPC8131 (USA)
- DPC8132 (USA)
- DPC6440 (USA)
- DPC6441 (USA)
- DPC7340 (USA)
- DPC7341 (USA)

995700585 (D, GB, F, E)

DPC6430, DPC6431, DPC7330, DPC7331, DPC8131,
 DPC8132, DPC6440, DPC6441, DPC7340, DPC7341,
 DPC6430, DPC7331, DPC8131, DPC8132, DPC6440
 , DPC7341 , DPC6430 , DPC6431 , DPC7330 , DPC7331
 , DPC8131 , DPC8132 , DPC6440 , DPC6441 ,
 DPC7340 , DPC7341

1

Tankeinheit und Handgriffe
 Tank and handle grips
 Réservoir et poignées
 Depósito y mangos

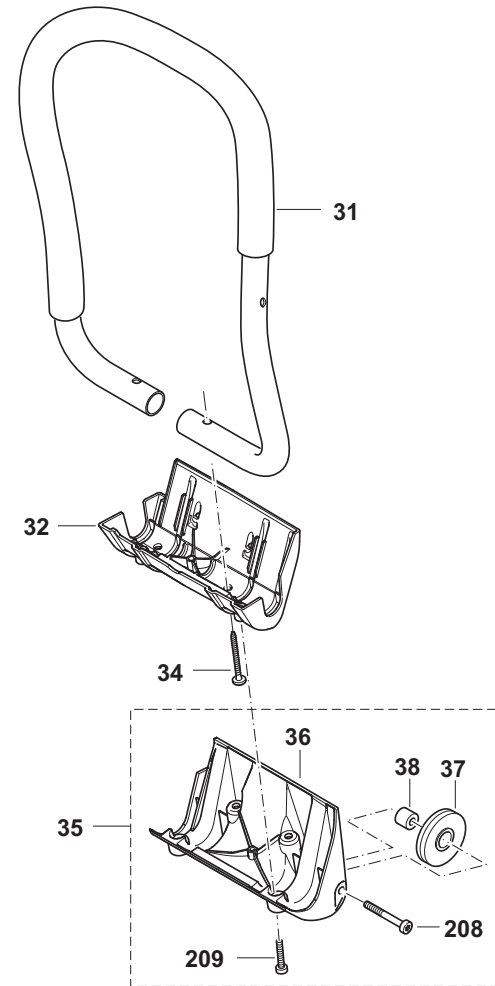
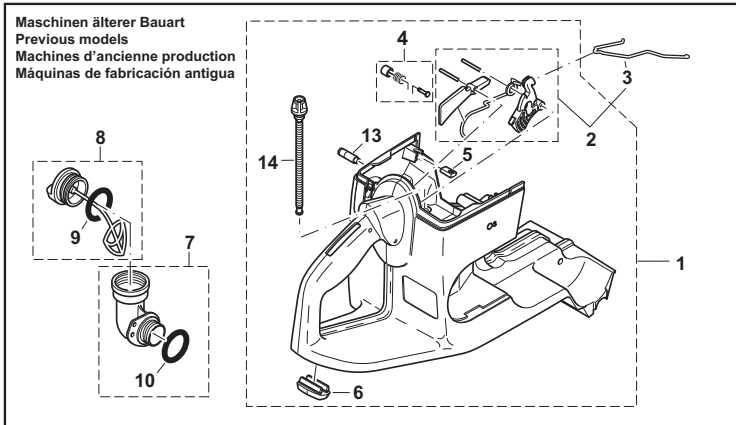
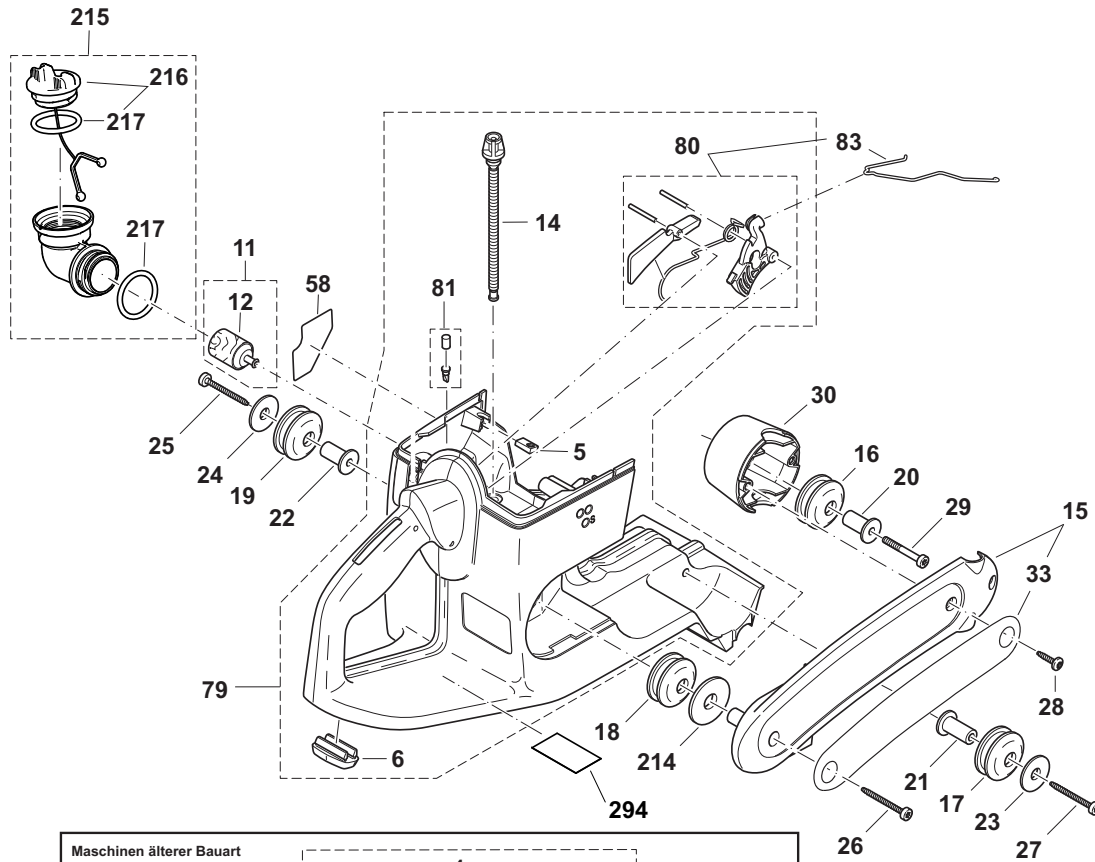

DPC6430, DPC6431, DPC7330, DPC7331, DPC8131, DPC8132, DPC6440, DPC6441, DPC7340, DPC7341, DPC6430, DPC7331, DPC8131, DPC8132, DPC6440, DPC7341, DPC6430, DPC6431, DPC7330, DPC7331, DPC8131, DPC8132, DPC6440, DPC6441, DPC7340, DPC7341

1

Tankeinheit und Handgriffe
Tank and handle grips
Réservoir et poignées
Depósito y mangos



Seite / Page	Pos.	DPC6430	DPC6431	DPC7330	DPC7331	DPC8131	DPC8132	DPC6440	DPC6441	DPC7340	DPC7341	DPC6430 (UK)	DPC7331 (UK)	DPC8131 (UK)	DPC8132 (UK)	DPC6440 (UK)	DPC7341 (UK)	DPC6430 (USA)	DPC6431 (USA)	DPC7330 (USA)	DPC7331 (USA)	DPC8131 (USA)	DPC8132 (USA)	DPC6440 (USA)	DPC6441 (USA)	DPC7340 (USA)	DPC7341 (USA)	Teil-Nr. Part No. No. de pièce No. de pieza	Hinweise Notes Renseign. Nota	Bezeichnung	Spezifikation Specification	Description	Désignation	Denominación
1	1	1	1	1	1	1	1	1	1	1	1	1	1	1	1	1	1	1	1	1	1	1	1	1	1	1	1	394 114 605		TANK KPL. MIT MECHANIK, BLAU	=> 2009	TANK CPL., BLUE	RÉSERVOIR CPL., BLEU	DEPÓSITO CPL.
1	2	1	1	1	1	1	1	1	1	1	1	1	1	1	1	1	1	1	1	1	1	1	1	1	1	1	1	957 117 020		GASMECHANIK KPL.		THROTTLE MECHANISM, CPL.	MÉCANIQUE DE DÉCLEN. CPL.	MECANISMO ACELERADOR, CPL.
1	3	1	1	1	1	1	1	1	1	1	1	1	1	1	1	1	1	1	1	1	1	1	1	1	1	1	1	394 117 011		GASGESTÄNGE		THROTTLE LINKAGE	TRINGLE D'ACCÉLÉRATION	VARILLA ACELERADOR
1	4	1	1	1	1	1	1	1	1	1	1	1	1	1	1	1	1	1	1	1	1	1	1	1	1	1	1	957 117 030		HALBGASARRERTIERUNG KPL.		HALF-THROTTLE LOCK, CPL.	DISPOS. D'ARRÊT DEMI-GAZ CPL.	BLOQUEO MEDIO GAS, CPL.
1	5	4	4	4	4	4	4	4	4	4	4	4	4	4	4	4	4	4	4	4	4	4	4	4	4	4	4	394 114 100		SCHRAUBEINSAATZ		SCREW PLUG	EMBOUT DE VISSAGE	ALOJAMIENTO DE TORNILLOS
1	6	1	1	1	1	1	1	1	1	1	1	1	1	1	1	1	1	1	1	1	1	1	1	1	1	1	1	394 114 070		GUMMIFUß		RUBBER FOOT	PIED, CAOTCHOU	PIE, GOMA
1	7	1	1	1	1	1	1	1	1	1	1	1	1	1	1	1	1	1	1	1	1	1	1	1	1	1	1	010 114 081	Acc.	WINKELTANKVERSCHLUß KPL.		ANGULAR UNION ASSY.	MANCHON COUDÉ CPL.	CIERRE ANGULAR CPL.
1	8	1	1	1	1	1	1	1	1	1	1	1	1	1	1	1	1	1	1	1	1	1	1	1	1	1	1	010 114 091		TANKDECKEL KPL., KRAFTSTOFF		TANK CAP CPL.	BOUCHON RÉSERVOIR CPL.	CIERRE DEPÓSITO CPL.
1	9	1	1	1	1	1	1	1	1	1	1	1	1	1	1	1	1	1	1	1	1	1	1	1	1	1	1	963 230 031		O-RING, ROT	ø30x3	O-RING, RED	BAGUE JOINT, ROUGE	ANILLO DE GUARNICIÓN, ROJO
1	10	1	1	1	1	1	1	1	1	1	1	1	1	1	1	1	1	1	1	1	1	1	1	1	1	1	1	963 230 031	Acc.	O-RING, ROT	ø30x3	O-RING, RED	BAGUE JOINT, ROUGE	ANILLO DE GUARNICIÓN, ROJO
1	11	1	1	1	1	1	1	1	1	1	1	1	1	1	1	1	1	1	1	1	1	1	1	1	1	1	1	963 601 122		SAUGKOPF KPL.		SUCTION HEAD	TÊTE D'ASPIRATION	CABEZA DE ASPIRACIÓN
1	12	1	1	1	1	1	1	1	1	1	1	1	1	1	1	1	1	1	1	1	1	1	1	1	1	1	1	963 601 240		FILZFILTER		FELT	FEUTRE	FIELTRO
1	13	1	1	1	1	1	1	1	1	1	1	1	1	1	1	1	1	1	1	1	1	1	1	1	1	1	1	010 175 050		BELÜFTUNGSVENTIL KPL.		AIR VALVE CPL.	SOUPAPE D'AERATION CPL.	VÁLVULA VENTILACION CPL.
1	14	1	1	1	1	1	1	1	1	1	1	1	1	1	1	1	1	1	1	1	1	1	1	1	1	1	1	965 404 912		SAUGSCHLAUCH KRAFTSTOFF	EPA code	FUEL LINE	CONDUITE CARB.	TUBO COMB.
1	15	1	1	1	1	1	1	1	1	1	1	1	1	1	1	1	1	1	1	1	1	1	1	1	1	1	1	394 114 661		SEITENSTREBE	MAKITA, grey	BRACKET	SUPPORT	SOPORTE
1	15	1	1	1	1	1	1	1	1	1	1	1	1	1	1	1	1	1	1	1	1	1	1	1	1	1	1	395 310 600	2010 =>	SEITENSTREBE, GEÄTZT	MAKITA, black, etched	BRACKET	SUPPORT	SOPORTE

DPC6430, DPC6431, DPC7330, DPC7331, DPC8131,
 DPC8132, DPC6440, DPC6441, DPC7340, DPC7341,
 DPC6430, DPC7331, DPC8131, DPC8132, DPC6440
 , DPC7341 , DPC6430 , DPC6431 , DPC7330 , DPC7331
 , DPC8131 , DPC8132 , DPC6440 , DPC6441 ,
 DPC7340 , DPC7341

1

Tankeinheit und Handgriffe
 Tank and handle grips
 Réservoir et poignées
 Depósito y mangos

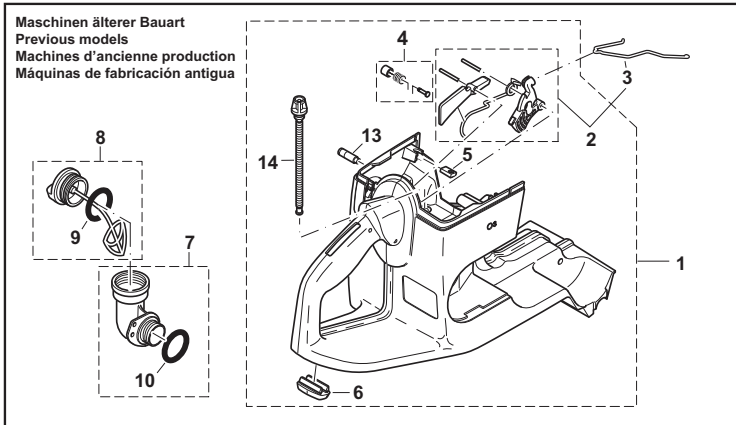
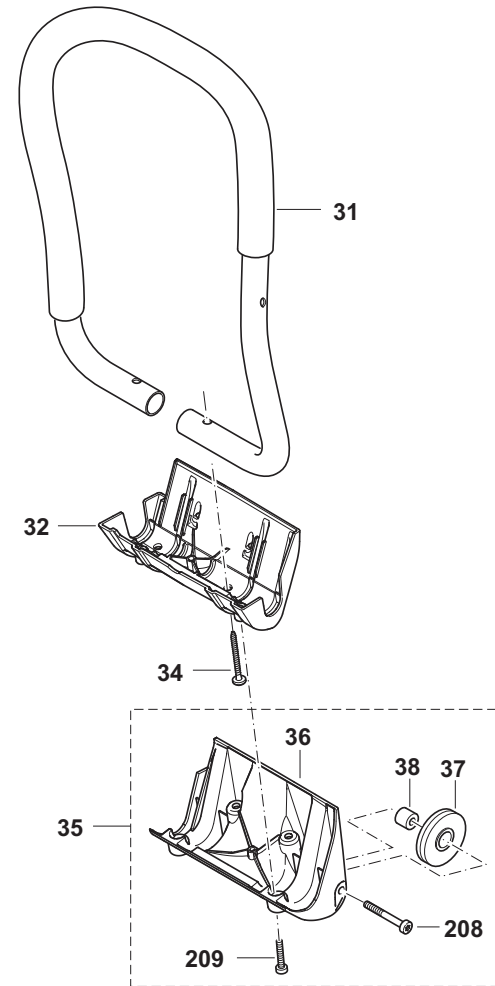
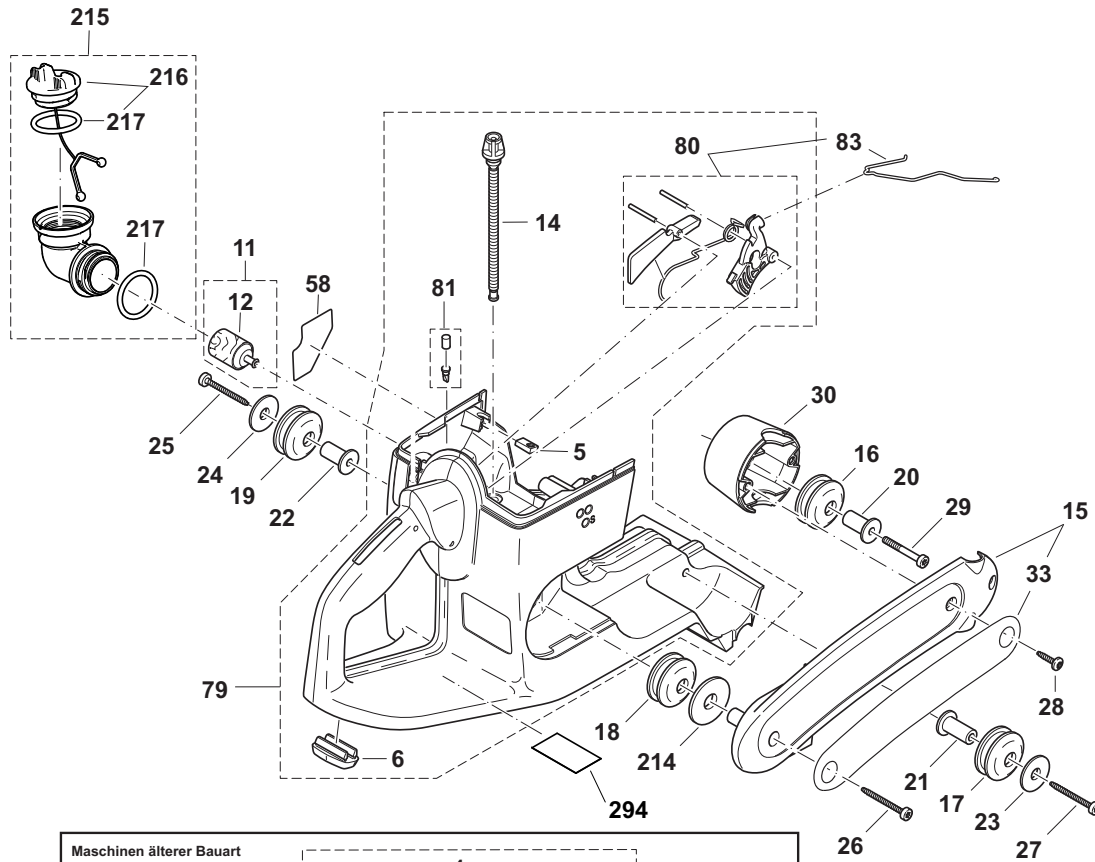

DPC6430, DPC6431, DPC7330, DPC7331, DPC8131, DPC8132, DPC6440, DPC6441, DPC7340, DPC7341, DPC6430, DPC7331, DPC8131, DPC8132, DPC6440, DPC7341, DPC6430, DPC6431, DPC7330, DPC7331, DPC8131, DPC8132, DPC6440, DPC6441, DPC7340, DPC7341

1

Tankeinheit und Handgriffe
Tank and handle grips
Réservoir et poignées
Depósito y mangos



Seite / Page	Pos.	DPC6430	DPC6431	DPC7330	DPC7331	DPC8131	DPC8132	DPC6440	DPC6441	DPC7340	DPC7341	DPC6430 (UK)	DPC7331 (UK)	DPC8131 (UK)	DPC8132 (UK)	DPC6440 (UK)	DPC7341 (UK)	DPC6430 (USA)	DPC6431 (USA)	DPC7330 (USA)	DPC7331 (USA)	DPC8131 (USA)	DPC8132 (USA)	DPC6440 (USA)	DPC6441 (USA)	DPC7340 (USA)	DPC7341 (USA)	Teil-Nr. Part No. No. de pièce No. de pieza	Hinweise Notes Renseign. Nota	Bezeichnung	Spezifikation Specification	Description	Désignation	Denominación	
1	16	1	1	1	1	1	1	1	1	1	1	1	1	1	1	1	1	1	1	1	1	1	1	1	1	1	1	1	965 403 535		SCHWINGUNGS DÄMPFER		RUBBER BUFFER	AMORTISSEU R	AMORTIGUAD OR
1	17	1	1	1	1	1	1	1	1	1	1	1	1	1	1	1	1	1	1	1	1	1	1	1	1	1	1	1	965 403 535		SCHWINGUNGS DÄMPFER		RUBBER BUFFER	AMORTISSEU R	AMORTIGUAD OR
1	18	1	1	1	1	1	1	1	1	1	1	1	1	1	1	1	1	1	1	1	1	1	1	1	1	1	1	1	965 403 535		SCHWINGUNGS DÄMPFER		RUBBER BUFFER	AMORTISSEU R	AMORTIGUAD OR
1	19	1	1	1	1	1	1	1	1	1	1	1	1	1	1	1	1	1	1	1	1	1	1	1	1	1	1	1	965 403 535		SCHWINGUNGS DÄMPFER		RUBBER BUFFER	AMORTISSEU R	AMORTIGUAD OR
1	20	1	1	1	1	1	1	1	1	1	1	1	1	1	1	1	1	1	1	1	1	1	1	1	1	1	1	1	394 114 281		ACHSE FÜR DÄMPFER		AXLE	AXE	EJE
1	21	1	1	1	1	1	1	1	1	1	1	1	1	1	1	1	1	1	1	1	1	1	1	1	1	1	1	1	394 114 281		ACHSE FÜR DÄMPFER		AXLE	AXE	EJE
1	22	1	1	1	1	1	1	1	1	1	1	1	1	1	1	1	1	1	1	1	1	1	1	1	1	1	1	1	394 114 281		ACHSE FÜR DÄMPFER		AXLE	AXE	EJE
1	23	1	1	1	1	1	1	1	1	1	1	1	1	1	1	1	1	1	1	1	1	1	1	1	1	1	1	1	900 005 078		ANLAGESCHEI BE		WASHER	RONDELLE	ARANDELA
1	24	1	1	1	1	1	1	1	1	1	1	1	1	1	1	1	1	1	1	1	1	1	1	1	1	1	1	1	900 005 078		ANLAGESCHEI BE		WASHER	RONDELLE	ARANDELA
1	25	1	1	1	1	1	1	1	1	1	1	1	1	1	1	1	1	1	1	1	1	1	1	1	1	1	1	1	913 455 454		SCHRAUBE	5,5x45	SCREW	VIS	TORNILLO
1	26	1	1	1	1	1	1	1	1	1	1	1	1	1	1	1	1	1	1	1	1	1	1	1	1	1	1	1	913 455 454		SCHRAUBE	5,5x45	SCREW	VIS	TORNILLO
1	27	1	1	1	1	1	1	1	1	1	1	1	1	1	1	1	1	1	1	1	1	1	1	1	1	1	1	1	913 455 454		SCHRAUBE	5,5x45	SCREW	VIS	TORNILLO
1	28	2	2	2	2	2	2	2	2	2	2	2	2	2	2	2	2	2	2	2	2	2	2	2	2	2	2	2	913 455 204		SCHRAUBE	5,5x20	SCREW	VIS	TORNILLO
1	29	1	1	1	1	1	1	1	1	1	1	1	1	1	1	1	1	1	1	1	1	1	1	1	1	1	1	1	908 305 405		INNENSTERN-S CHRAUBE	M5x20x40	SCREW	VIS	TORNILLO
1	30	1	1	1	1	1	1	1	1	1	1	1	1	1	1	1	1	1	1	1	1	1	1	1	1	1	1	1	395 310 020	2010 =>	AUFNAHMETOP F, SCHWARZ, GEÄTZT	black, etched	POT	CAPUCHON	POTE
1	30	1	1	1	1	1	1	1	1	1	1	1	1	1	1	1	1	1	1	1	1	1	1	1	1	1	1	1	394 114 051		AUFNAHMETOP F FÜR DÄMPFER, GRAU		POT	CAPUCHON	POTE
1	31	1	1	1	1	1	1	1	1	1	1	1	1	1	1	1	1	1	1	1	1	1	1	1	1	1	1	1	394 310 100		RUNDUMGRIFF KPL.		WRAP AROUND HANDLE	POIGNÉE CIRCULAIRE	MANGO CIRCULAR
1	32	1	1	1	1	1	1	1	1	1	1	1	1	1	1	1	1	1	1	1	1	1	1	1	1	1	1	1	394 114 190		STANDFUß		FOOT	PIED	PIE
1	33	1	1	1	1	1	1	1	1	1	1	1	1	1	1	1	1	1	1	1	1	1	1	1	1	1	1	1	980 115 215		SCHILD	MAKITA	LABEL	PLAQUE	CALCOMANIA
1	34	2	2	2	2	2	2	2	2	2	2	2	2	2	2	2	2	2	2	2	2	2	2	2	2	2	2	2	913 455 454		SCHRAUBE	5,5x45	SCREW	VIS	TORNILLO
1	35	1	1	1	1	1	1	1	1	1	1	1	1	1	1	1	1	1	1	1	1	1	1	1	1	1	1	1	394 114 272	Acc.	STANDFUß MIT ROLLEN KPL.		FOOT CPL.	PIED CPL.	PIE CPL.
1	36																												394 114 251		STANDFUß		FOOT	PIED	PIE
1	37	2	2	2	2	2	2	2	2	2	2	2	2	2	2	2	2	2	2	2	2	2	2	2	2	2	2	2	394 114 230	Acc.	ROLLE		ROLLER	ROULEAU	RUEDA
1	38	2	2	2	2	2	2	2	2	2	2	2	2	2	2	2	2	2	2	2	2	2	2	2	2	2	2	2	394 114 240	Acc.	BUCHSE		BUSHING	DOUILLE	CASQUILLO

DPC6430, DPC6431, DPC7330, DPC7331, DPC8131,
 DPC8132, DPC6440, DPC6441, DPC7340, DPC7341,
 DPC6430, DPC7331, DPC8131, DPC8132, DPC6440
 , DPC7341 , DPC6430 , DPC6431 , DPC7330 , DPC7331
 , DPC8131 , DPC8132 , DPC6440 , DPC6441 ,
 DPC7340 , DPC7341

1

Tankeinheit und Handgriffe
 Tank and handle grips
 Réservoir et poignées
 Depósito y mangos

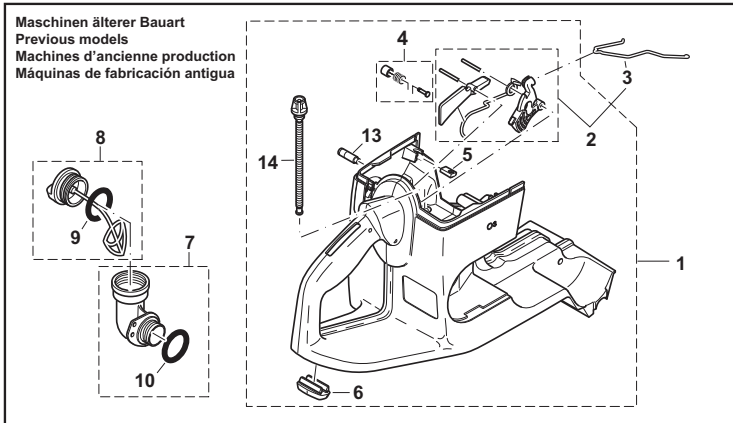
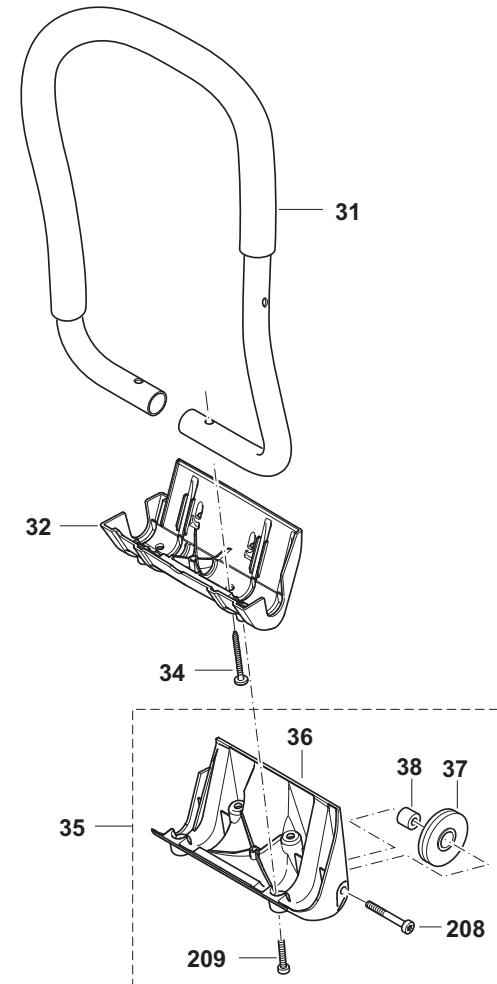
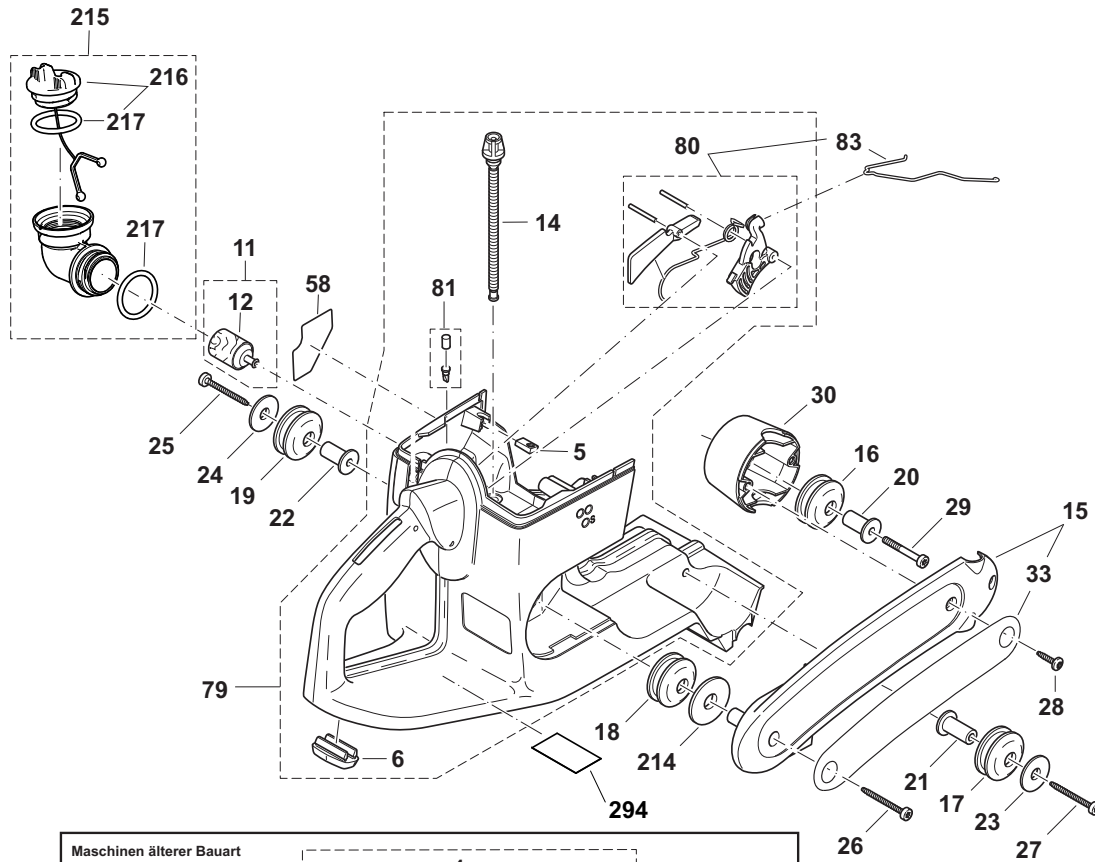

DPC6430, DPC6431, DPC7330, DPC7331, DPC8131, DPC8132, DPC6440, DPC6441, DPC7340, DPC7341, DPC6430, DPC7331, DPC8131, DPC8132, DPC6440, DPC7341, DPC6430, DPC6431, DPC7330, DPC7331, DPC8131, DPC8132, DPC6440, DPC6441, DPC7340, DPC7341

1

Tankeinheit und Handgriffe
Tank and handle grips
Réservoir et poignées
Depósito y mangos



Seite / Page	Pos.	DPC6430	DPC6431	DPC7330	DPC7331	DPC8131	DPC8132	DPC6440	DPC6441	DPC7340	DPC7341	DPC6430 (UK)	DPC7331 (UK)	DPC8131 (UK)	DPC8132 (UK)	DPC6440 (UK)	DPC7341 (UK)	DPC6430 (USA)	DPC6431 (USA)	DPC7330 (USA)	DPC7331 (USA)	DPC8131 (USA)	DPC8132 (USA)	DPC6440 (USA)	DPC6441 (USA)	DPC7340 (USA)	DPC7341 (USA)	Teil-Nr. Part No. No. de pièce No. de pieza	Hinweise Notes Renseign. Nota	Bezeichnung	Spezifikation Specification	Description	Désignation	Denominación	
1	58																	1	1	1	1	1	1	1	1	1	1	1	980 115 100		AUFKLEBER	MIX, USA-CDN-AUS	LABEL	ÉTIQUETTE	ETIQUETA
1	79	1	1	1	1	1	1	1	1	1	1	1	1	1	1	1	1											395 114 600	2010 =>	TANK KPL. MIT MECHANIK, BLAU	blue, highly polished	TANK CPL., BLUE	RÉSERVOIR CPL., BLEU	DEPÓSITO CPL.	
1	79																	1	1	1	1	1	1	1	1	1	1	395 114 640		TANK KPL. MIT MECHANIK, BLAU	USA (EPA), INCL.294	TANK CPL., BLUE	RÉSERVOIR CPL., BLEU	DEPÓSITO CPL.	
1	80	1	1	1	1	1	1	1	1	1	1	1	1	1	1	1	1	1	1	1	1	1	1	1	1	1	1	957 117 040		GASMECHANIK KPL.		THROTTLE MECHANISM, CPL.	MÉCANIQUE DE DÉCLEN. CPL.	MECANISMO ACELERADOR, CPL.	
1	81	1	1	1	1	1	1	1	1	1	1	1	1	1	1	1	1	1	1	1	1	1	1	1	1	1	1	170 175 010		SATZ BELÜFTUNGSVENTIL		AIR VALVE CPL.	SOUPAPE D'AERATION CPL.	VÁLVULA VENTILACION CPL.	
1	83	1	1	1	1	1	1	1	1	1	1	1	1	1	1	1	1	1	1	1	1	1	1	1	1	1	1	395 117 010		GASGESTÄNGE		THROTTLE LINKAGE	TRINGLE D'ACCÉLÉRATION	VARILLA ACELERADOR	
1	208	2	2	2	2	2	2	2	2	2	2	2	2	2	2	2	2	2	2	2	2	2	2	2	2	2	2	2	908 006 356	Acc.	SCHRAUBE	M6X35	SCREW	VIS	TORNILLO
1	209	4	4	4	4	4	4	4	4	4	4	4	4	4	4	4	4	4	4	4	4	4	4	4	4	4	4	4	908 905 165		INNENSTERN-SCHRAUBE	5x16	SCREW	VIS	TORNILLO
1	214	1	1	1	1	1	1	1	1	1	1	1	1	1	1	1	1	1	1	1	1	1	1	1	1	1	1	900 005 076		ANLAGESCHEIBE		WASHER	RONDELLE	ARANDELA	
1	215	1	1	1	1	1	1	1	1	1	1	1	1	1	1	1	1	1	1	1	1	1	1	1	1	1	1	395 114 300	Acc.	WINKELTANKVERSCHLUß KPL.		ANGULAR UNION ASSY.	MANCHON COUDÉ CPL.	CIERRE ANGULAR CPL.	
1	216	1	1	1	1	1	1	1	1	1	1	1	1	1	1	1	1	1	1	1	1	1	1	1	1	1	1	181 114 202		TANKDECKEL KPL.		TANK CAP CPL.	BOUCHON RÉSERVOIR CPL.	TORNILLO DE CIERRE CPL.	
1	217	2	2	2	2	2	2	2	2	2	2	2	2	2	2	2	2	2	2	2	2	2	2	2	2	2	2	963 229 036		O-RING	29,3X3,6	PACKING RING	BAGUE-JOINT	ANILLO DE GUARNICION	
1	294																	1	1	1	1	1	1	1	1	1	1			AUFKLEBER TANK	USA - EVAPORATION MAKITA	LABEL, TANK	PLAQUE, RÉSERVOIR	CALCOMANIA, DEPÓSITO	

DPC6430, DPC6431, DPC7330, DPC7331, DPC8131,
DPC8132, DPC6440, DPC6441, DPC7340, DPC7341,
DPC6430, DPC7331, DPC8131, DPC8132, DPC6440
, DPC7341, DPC6430, DPC6431, DPC7330, DPC7331
, DPC8131, DPC8132, DPC6440, DPC6441,
DPC7340, DPC7341

2

Abdeckhaube, Luftfilter
Hood, air filter
Capot protecteur, filtre à air
Cubierta protectora, filtro de aire

Makita[®]

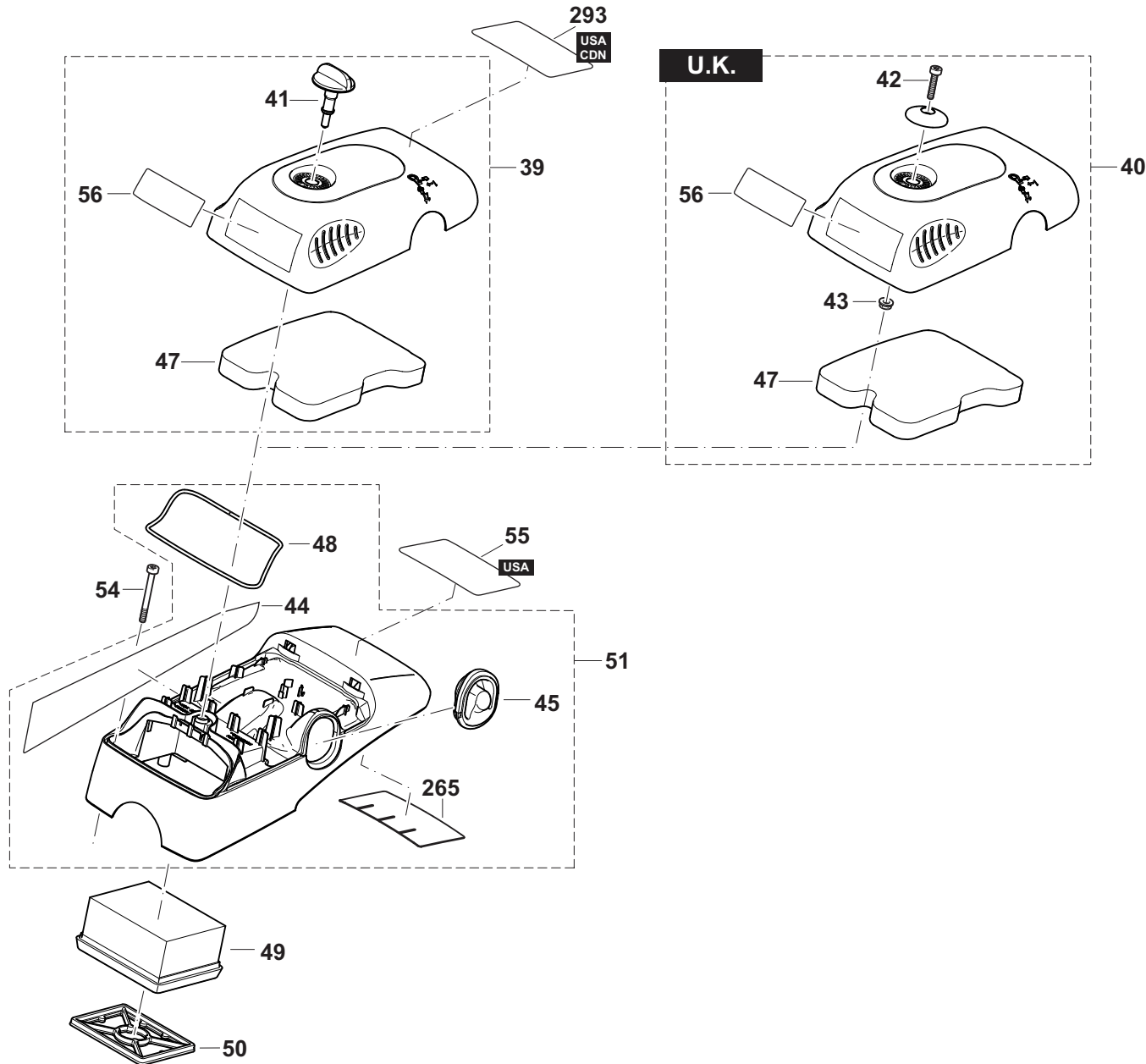

DPC6430, DPC6431, DPC7330, DPC7331, DPC8131, DPC8132, DPC6440, DPC6441, DPC7340, DPC7341, DPC6430, DPC7331, DPC8131, DPC8132, DPC6440, DPC7341, DPC6430, DPC6431, DPC7330, DPC7331, DPC8131, DPC8132, DPC6440, DPC6441, DPC7340, DPC7341

2

Abdeckhaube, Luftfilter
Hood, air filter
Capot protecteur, filtre à air
Cubierta protectora, filtro de aire



Seite / Page	Pos.	DPC6430	DPC6431	DPC7330	DPC7331	DPC8131	DPC8132	DPC6440	DPC6441	DPC7340	DPC7341	DPC6430 (UK)	DPC7331 (UK)	DPC8131 (UK)	DPC8132 (UK)	DPC6440 (UK)	DPC7341 (UK)	DPC6430 (USA)	DPC6431 (USA)	DPC7330 (USA)	DPC7331 (USA)	DPC8131 (USA)	DPC8132 (USA)	DPC6440 (USA)	DPC6441 (USA)	DPC7340 (USA)	DPC7341 (USA)	Teil-Nr. Part No. No. de pièce No. de pieza	Hinweise Notes Renseign. Nota	Bezeichnung	Spezifikation Specification	Descriptio n	Désignation	Denominación
2	39	1	1	1	1	1	1	1	1	1	1							1	1	1	1	1	1	1	1	1	1	395 118 121	2010 =>	FILTERDECKE L KPL., SCHWARZ, GEÄTZT	black, etched, incl. Pos. 47	COVER ASSY.	CAPOT CPL.	CUBIERTA CPL.
2	39	1	1	1	1	1	1	1	1	1	1							1	1	1	1	1	1	1	1	1	395 118 610		FILTERDECKE L KPL., GRAU	grey, w/o Pos. 47	COVER ASSY.	CAPOT CPL.	CUBIERTA CPL.	
2	39	1	1	1	1	1	1																				395 118 190	RU	FILTERDECKE L KPL., SCHWARZ, GEÄTZT	black, etched, incl. Pos. 47	COVER ASSY.	CAPOT CPL.	CUBIERTA CPL.	
2	40											1	1	1	1	1	1											957 118 020	U.K. 2010 =>	FILTERDECKE L KPL., SCHWARZ, GEÄTZT	black, etched, incl. Pos. 47	FILTER COVER ASSY.	CAPOT FILTRE CPL.	CUBIERTA P. FILTRE CPL.
2	40											1	1	1	1	1	1											395 118 660	U.K.	FILTERDECKE L KPL., GRAU	grey, w/o Pos. 47	COVER ASSY.	CAPOT CPL.	CUBIERTA CPL.
2	41	1	1	1	1	1	1	1	1	1	1							1	1	1	1	1	1	1	1	1	1	395 118 010		VERSCHLUßKNOFF		FIXING	FERMETURE	CIERRE
2	42											1	1	1	1	1	1											395 118 131	U.K.	SENKKOPFSCHE HRAUBE	M6x50	COUNTERSUNK SCREW	BOULON À TÊTE FRAISÉE	TORNILLO DE CABEZA AVELLANADA
2	43											1	1	1	1	1	1											920 406 000	U.K.	SECHSKANTMUTTER	M6	HEX NUT	ECROU HEXAGONAL	TUERCA HEXAGONAL
2	44	1	1	1	1	1	1	1	1	1	1	1	1	1	1	1	1	1	1	1	1	1	1	1	1	1	1	980 115 717		SICHERHEITS-AUFKLEBER		SAFETY LABEL	PLAQUE	CALCOMANIA
2	44	1	1	1	1	1	1																					980 115 618	RU	SICHERHEITS-AUFKLEBER		SAFETY LABEL	PLAQUE	CALCOMANIA
2	45	1	1	1	1	1	1	1	1	1	1	1	1	1	1	1	1	1	1	1	1	1	1	1	1	1	1	395 118 050		GUMMITEIL	DEKO	RUBBER PART	ÉLASTIQUE PART	PIEZA DE GOMA ELÁSTICA
2	47	1	1	1	1			1	1	1	1	1	1					1	1	1	1							395 173 080		VORFILTER		PREFILTER	PREFILTRE	PRIMER FILTRO
2	47				1	1								1	1							1	1					395 173 090		VORFILTER, GEÖLT		PREFILTER	PREFILTRE	PRIMER FILTRO
2	47				1	1																1	1					957 173 610		FILTERSET 5+1 GEÖLT	MAKITA INC. 5x47 + 1x49	FILTER-SET	JEU DE FILTRE POUR DECOUPEUSE	JUEGO DE FILTROS CORTADORAS
2	48	1	1	1	1	1	1	1	1	1	1	1	1	1	1	1	1	1	1	1	1	1	1	1	1	1	1	395 118 021		DICHTSCHNUR		PACKING RING	BAGUE-JOINT	ANILLO DE GUARNICIÓN
2	49	1	1	1	1	1	1	1	1	1	1	1	1	1	1	1	1	1	1	1	1	1	1	1	1	1	1	395 173 010		LUFTFILTEREINSATZ		AIR FILTER	FILTRE À AIR	FILTRO DE AIRE

DPC6430, DPC6431, DPC7330, DPC7331, DPC8131,
DPC8132, DPC6440, DPC6441, DPC7340, DPC7341,
DPC6430, DPC7331, DPC8131, DPC8132, DPC6440
, DPC7341, DPC6430, DPC6431, DPC7330, DPC7331
, DPC8131, DPC8132, DPC6440, DPC6441,
DPC7340, DPC7341

2

Abdeckhaube, Luftfilter
Hood, air filter
Capot protecteur, filtre à air
Cubierta protectora, filtro de aire

Makita[®]

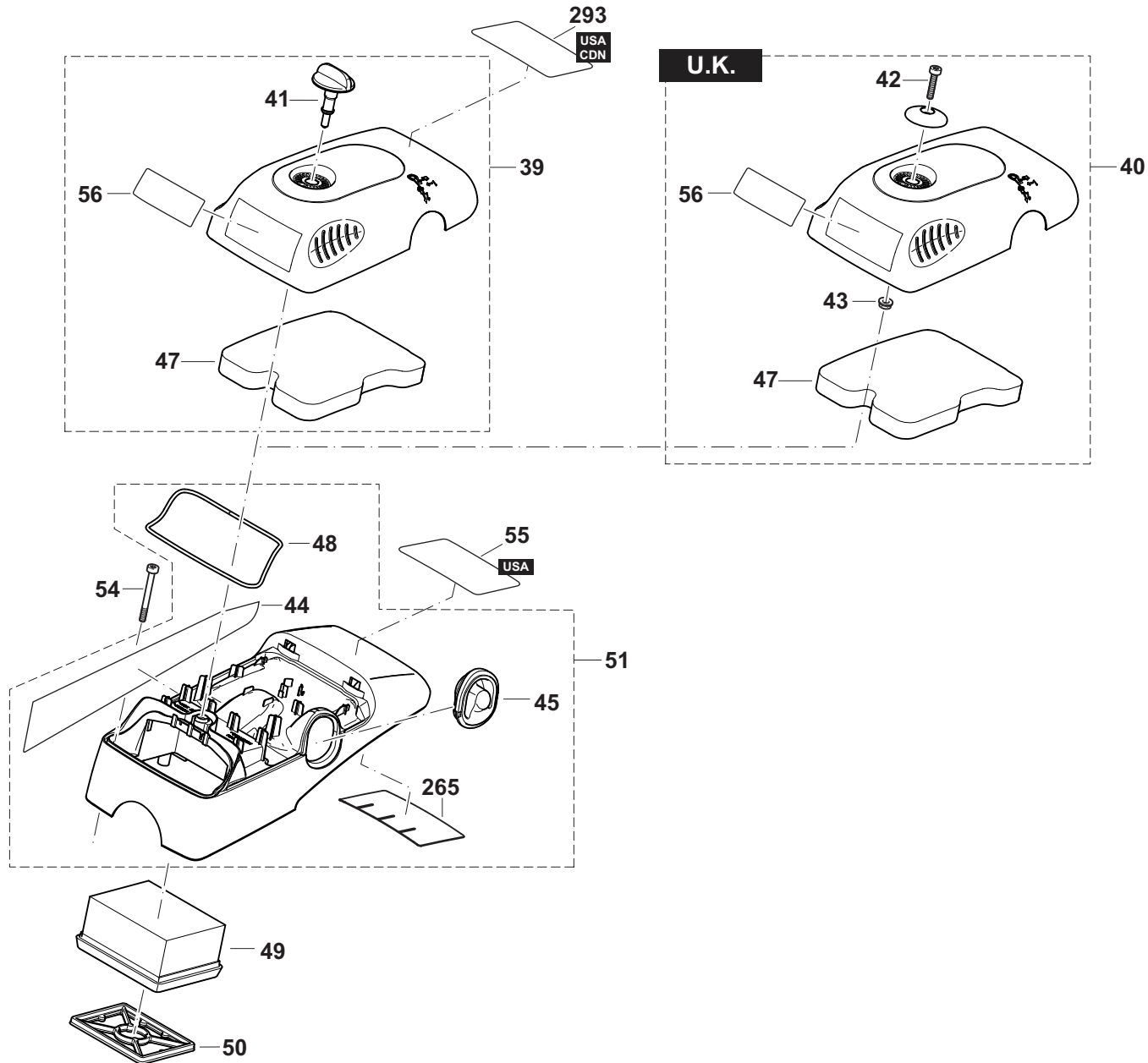

DPC6430, DPC6431, DPC7330, DPC7331, DPC8131, DPC8132, DPC6440, DPC6441, DPC7340, DPC7341, DPC6430, DPC7331, DPC8131, DPC8132, DPC6440, DPC7341, DPC6430, DPC6431, DPC7330, DPC7331, DPC8131, DPC8132, DPC6440, DPC6441, DPC7340, DPC7341

2

Abdeckhaube, Luftfilter
Hood, air filter
Capot protecteur, filtre à air
Cubierta protectora, filtro de aire



Seite / Page	Pos.	DPC6430	DPC6431	DPC7330	DPC7331	DPC8131	DPC8132	DPC6440	DPC6441	DPC7340	DPC7341	DPC6430 (UK)	DPC7331 (UK)	DPC8131 (UK)	DPC8132 (UK)	DPC6440 (UK)	DPC7341 (UK)	DPC6430 (USA)	DPC6431 (USA)	DPC7330 (USA)	DPC7331 (USA)	DPC8131 (USA)	DPC8132 (USA)	DPC6440 (USA)	DPC6441 (USA)	DPC7340 (USA)	DPC7341 (USA)	Teil-Nr. Part No. No. de pièce No. de pieza	Hinweise Notes Renseign. Nota	Bezeichnung	Spezifikation Specification	Descriptio n	Désignation	Denominación
2	49					1	1							1	1							1	1					957 173 610		FILTERSET 5+1 GEÖLT	MAKITA INC. 5x47 + 1x49	FILTER-S ET	JEU DE FILTRE POUR DECOUPEUSE	JUEGO DE FILTROS CORTADORAS
2	50	1	1	1	1	1	1	1	1	1	1	1	1	1	1	1	1	1	1	1	1	1	1	1	1	1	1	395 173 020		INNENFILTER		INNER FILTER	FILTRE INTÉRIEUR	FILTRO DE AIRE INTERIOR
2	51	1	1	1	1	1	1	1	1	1	1	1	1	1	1	1	1	1	1	1	1	1	1	1	1	1	395 118 093	2010 =>	ABDECKHAUB E KPL., SCHWARZ, GEÄTZT	KAT, etched	HOOD CPL.	CAPOT CPL.	TAPA CPL.	
2	51	1	1	1	1	1	1																				395 118 210	RU	ABDECKHAUB E KPL., SCHWARZ, GEÄTZT	black, etched	HOOD CPL.	CAPOT CPL.	TAPA CPL.	
2	54	4	4	4	4	4	4	4	4	4	4	4	4	4	4	4	4	4	4	4	4	4	4	4	4	4	4	908 605 505		INNENSTERN- SCHRAUBE	M5x50	SCREW	VIS	TORNILLO
2	55																										1	980 115 477	U.S.A.	AUFKLEBER ABDECKHAUB E	DPC7341	LABEL	PLAQUE	CALCOMANIA
2	56	1	1	1	1	1	1	1	1	1	1	1	1	1	1	1	1	1	1	1	1	1	1	1	1	1	980 114 999		SCHILD	MIX	LABEL	PLAQUE	CALCOMANIA	
2	56	1	1	1	1	1	1																				980 115 617	RU	SCHILD	MIX	LABEL	PLAQUE	CALCOMANIA	
2	265							1	1	1	1				1	1											326 118 060		HITZEFOLIE		THERMAL FILM	FILM DE CHALEUR	FOLIO AL CALOR	
2	293																	1	1	1	1	1	1	1	1	1	980 115 607		STARTAUFKLE BER	USA	LABEL	PLAQUE	CALCOMANIA	
2	293																	1	1	1	1	1	1	1	1	1	980 115 602		STARTAUFKLE BER	CDN	LABEL	PLAQUE	CALCOMANIA	

DPC6430, DPC6431, DPC7330, DPC7331, DPC8131,
 DPC8132, DPC6440, DPC6441, DPC7340, DPC7341,
 DPC6430, DPC7331, DPC8131, DPC8132, DPC6440
 , DPC7341, DPC6430, DPC6431, DPC7330, DPC7331
 , DPC8131, DPC8132, DPC6440, DPC6441,
 DPC7340, DPC7341

3

Schalldämpfer
 Muffler
 Pot d' échappement
 Silencioso

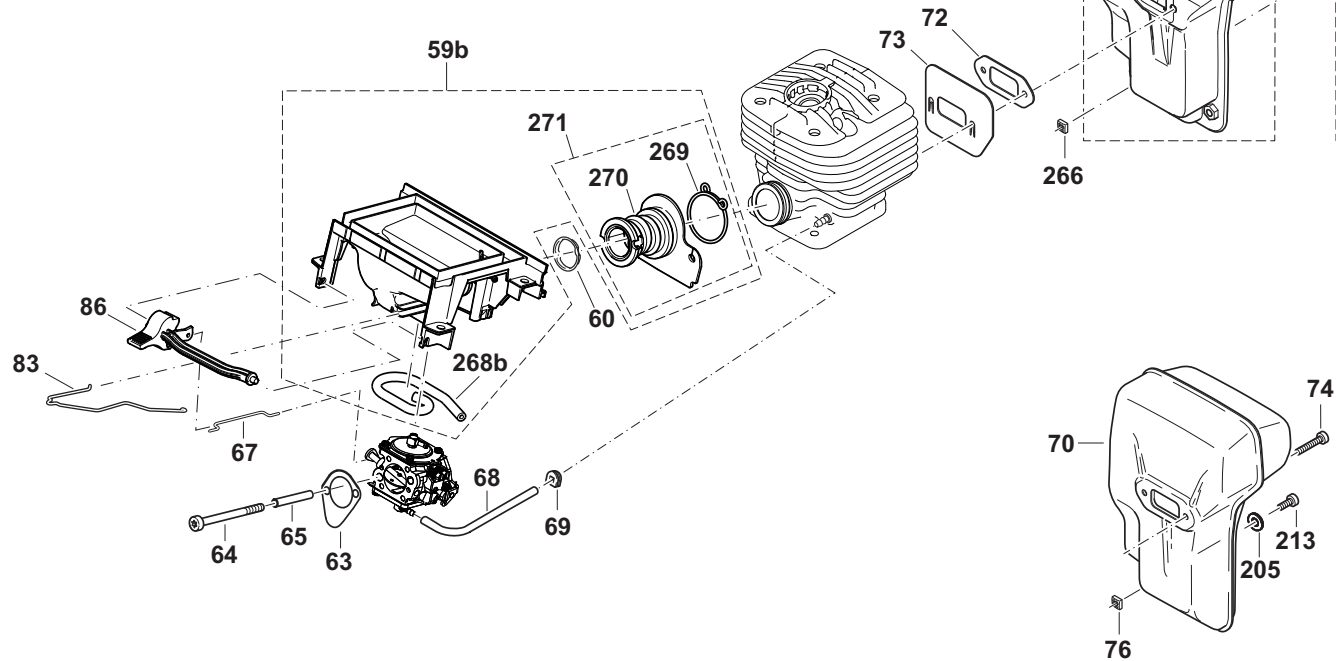
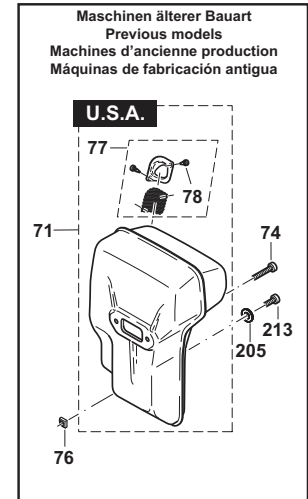
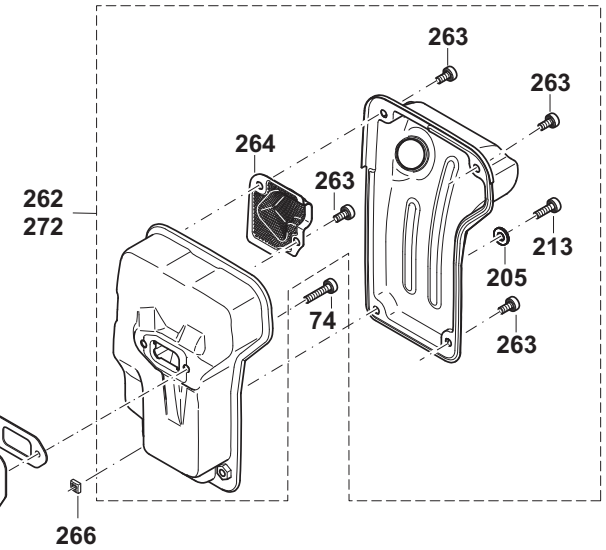
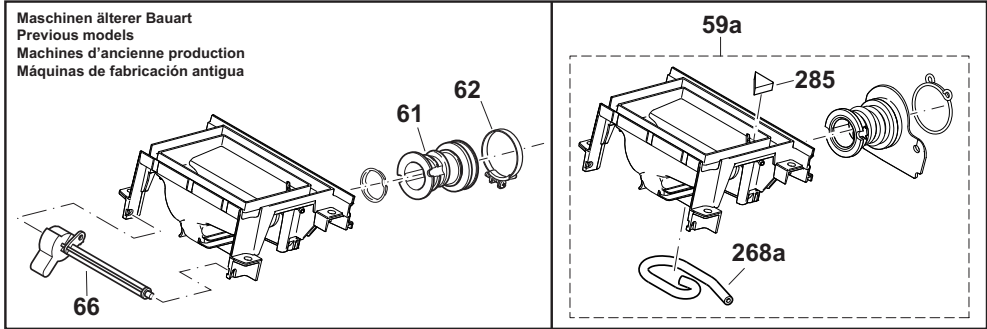

DPC6430, DPC6431, DPC7330, DPC7331, DPC8131, DPC8132, DPC6440, DPC6441, DPC7340, DPC7341, DPC6430, DPC7331, DPC8131, DPC8132, DPC6440, DPC7341, DPC6430, DPC6431, DPC7330, DPC7331, DPC8131, DPC8132, DPC6440, DPC6441, DPC7340, DPC7341

3

Schalldämpfer
Muffler
Pot d' échappement
Silencioso



Seite / Page	Pos.	DPC6430	DPC6431	DPC7330	DPC7331	DPC8131	DPC8132	DPC6440	DPC6441	DPC7340	DPC7341	DPC6430 (UK)	DPC7331 (UK)	DPC8131 (UK)	DPC8132 (UK)	DPC6440 (UK)	DPC7341 (UK)	DPC6430 (USA)	DPC6431 (USA)	DPC7330 (USA)	DPC7331 (USA)	DPC8131 (USA)	DPC8132 (USA)	DPC6440 (USA)	DPC6441 (USA)	DPC7340 (USA)	DPC7341 (USA)	Teil-Nr. Part No. No. de pièce No. de pieza	Hinweise Notes Renseign. Nota	Bezeichnung	Spezifikation Specification	Description	Désignation	Denominación
3	59a	1	1	1	1	1	1	1	1	1	1	1	1	1	1	1	1	1	1	1	1	1	1	1	1	1	1	395 171 071		ANSAUGKRÜMME R KPL.		CONNECTING MUFF CPL.	MANCHON DE JONCTION CPL.	MANGUITO DE CONEXIÓN CPL.
3	59b	1	1	1	1	1	1	1	1	1	1	1	1	1	1	1	1	1	1	1	1	1	1	1	1	1	395 171 072		ANSAUGKRÜMME R KPL.		CONNECTING MUFF CPL.	MANCHON DE JONCTION CPL.	MANGUITO DE CONEXIÓN CPL.	
3	60	1	1	1	1	1	1	1	1	1	1	1	1	1	1	1	1	1	1	1	1	1	1	1	1	1	024 131 032		EINSATZ FÜR ANSAUGSCHLAUCH H		INSERT FOR SUCTION HOSE	PIÈCE P. TUYAU	SUPLEMENTO P. TUBO	
3	61	1	1	1	1	1	1	1	1	1	1	1	1	1	1	1	1	1	1	1	1	1	1	1	1	1	394 131 101		ANSAUGSCHLAUCH H		SUCTION LINE	CONDUITE D' ASPIRATION	CONDUCTO DE ASPIRACIÓN	
3	62	1	1	1	1	1	1	1	1	1	1	1	1	1	1	1	1	1	1	1	1	1	1	1	1	1	965 603 050		SCHLAUCHSCHELLE		HOSE CLIP	COLLIER DE SERRAGE	ABRAZADERA	
3	63	1	1	1	1	1	1	1	1	1	1	1	1	1	1	1	1	1	1	1	1	1	1	1	1	1	965 518 120		DICHTUNG		GASKET	JOINT	JUNTA	
3	64	2	2	2	2	2	2	2	2	2	2	2	2	2	2	2	2	2	2	2	2	2	2	2	2	2	2	908 204 555		INNENSTERN-SCHRAUBE	M4x55	SCREW	VIS	TORNILLO
3	65	m	m	m	m	m	m	m	m	m	m	m	m	m	m	m	m	m	m	m	m	m	m	m	m	m	m	970 502 050		SCHLAUCH	37mm; 1 1/2"	TUBE	GAINE	TUBO
3	66	1	1	1	1	1	1	1	1	1	1	1	1	1	1	1	1	1	1	1	1	1	1	1	1	1	394 150 030		CHOKEWELLE		CHOKE SHAFT	AXE	EJE	
3	67	1	1	1	1	1	1	1	1	1	1	1	1	1	1	1	1	1	1	1	1	1	1	1	1	1	394 150 042		CHOKESTANGE		CHOKE SHAFT	LEVIER	PALANCE	
3	68	m	m	m	m	m	m	m	m	m	m	m	m	m	m	m	m	m	m	m	m	m	m	m	m	m	m	965 452 382		SCHLAUCH	120mm; 4 3/4"	TUBE	GAINE	TUBO
3	69	1	1	1	1	1	1	1	1	1	1	1	1	1	1	1	1	1	1	1	1	1	1	1	1	1	965 401 016		GUMMITÜLLE		RUBBER BUSH	GAINE CAOUTCHOUC	BOQUILLA DE CAUCHO	
3	70	1	1	1	1	1						1	1	1	1												394 174 401		SCHALLDÄMPFER KPL.		MUFFLER	POT D' ÉCHAPPEMENT	SILENCIADOR	
3	71																	1	1	1	1	1					394 174 152	U.S.A.	SCHALLDÄMPFER	USA	MUFFLER	POT D' ÉCHAPPEMENT	SILENCIADOR	
3	72	1	1	1	1	1	1	1	1	1	1	1	1	1	1	1	1	1	1	1	1	1	1	1	1	1	1	965 531 131		DICHTUNG		GASKET	JOINT	JUNTA
3	73	1	1	1	1	1	1	1	1	1	1	1	1	1	1	1	1	1	1	1	1	1	1	1	1	1	1	395 174 110		ABSCHIRMBLECH		COOLING PLATE	TÔLE DE PROTECTION	CHAPA DEFLECTORA
3	74	2	2	2	2	2	2	2	2	2	2	2	2	2	2	2	2	2	2	2	2	2	2	2	2	2	2	908 405 205		INNENSTERN-SCHRAUBE	M5x20	SCREW	VIS	TORNILLO
3	76	1	1	1	1	1						1	1	1	1												038 111 060		4KT-MUTTER	M5, SW10	SQUARE NUT	ECROU CARRÉ	TUERCA CUADR.	
3	77																	1	1	1	1	1					394 174 142	U.S.A.	FUNKENSCHUTZSIEB		SPARK ARRESTER SCREEN	TAMIS	TAMIZ	
3	78																	2	2	2	2	2					915 035 120	U.S.A.	SCHRAUBE		SCREW	VIS	TORNILLO	
3	83	1	1	1	1	1	1	1	1	1	1	1	1	1	1	1	1	1	1	1	1	1	1	1	1	1	1	395 117 010		GASGESTÄNGE		THROTTLE LINKAGE	TRINGLE D' ACCÉLÉRATION	VARILLA ACELERADOR
3	86	1	1	1	1	1	1	1	1	1	1	1	1	1	1	1	1	1	1	1	1	1	1	1	1	1	1	395 150 011		CHOKEWELLE		CHOKE LEVER	LEVIER DE STARTER	PALANCA ESTRANGUL. AIRE
3	205	1	1	1	1	1	1	1	1	1	1	1	1	1	1	1	1	1	1	1	1	1	1	1	1	1	1	928 405 000		SPANNSCHEIBE		DISC	DISQUE	ARANDELA
3	213	1	1	1	1	1	1	1	1	1	1	1	1	1	1	1	1	1	1	1	1	1	1	1	1	1	1	908 005 125		INNENSTERN-SCHRAUBE	M5x12	SCREW	VIS	TORNILLO

DPC6430, DPC6431, DPC7330, DPC7331, DPC8131,
 DPC8132, DPC6440, DPC6441, DPC7340, DPC7341,
 DPC6430, DPC7331, DPC8131, DPC8132, DPC6440
 , DPC7341, DPC6430, DPC6431, DPC7330, DPC7331
 , DPC8131, DPC8132, DPC6440, DPC6441,
 DPC7340, DPC7341

3

Schalldämpfer
 Muffler
 Pot d' échappement
 Silencioso

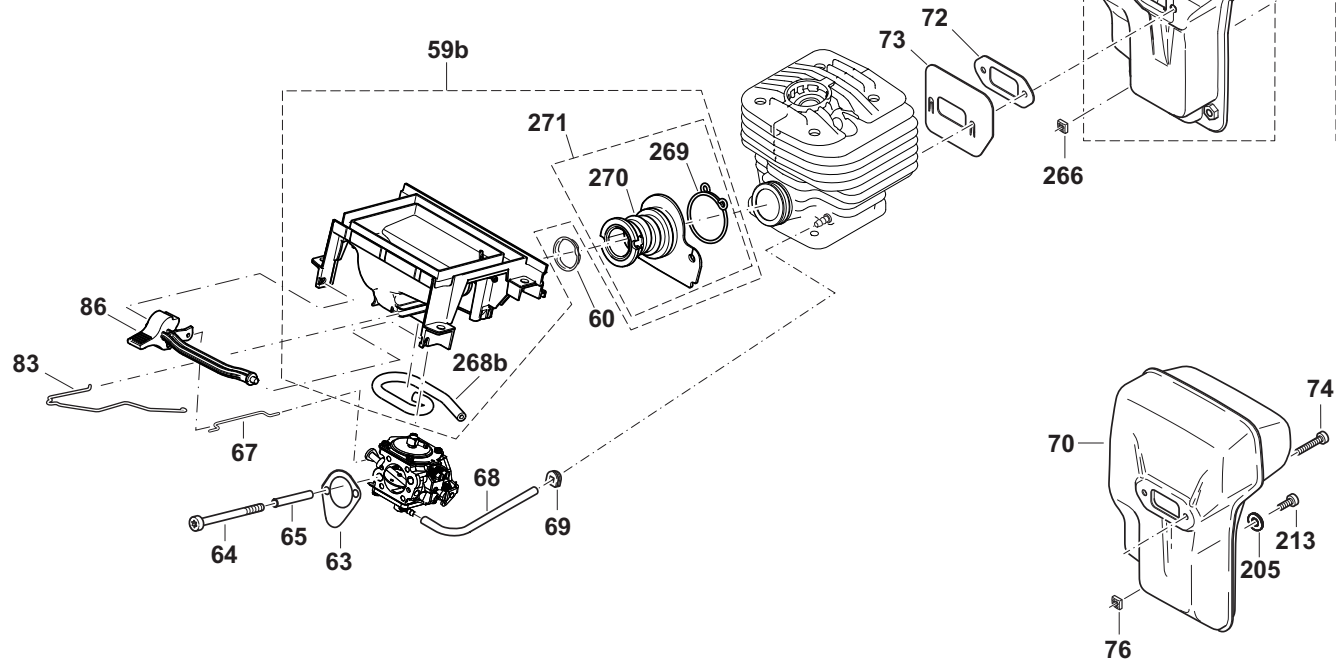
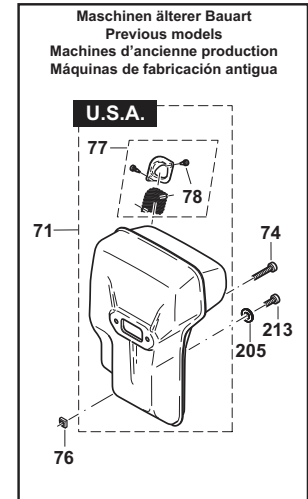
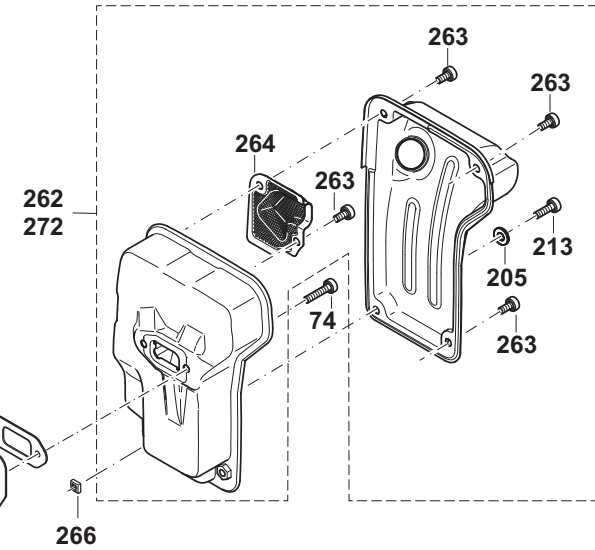
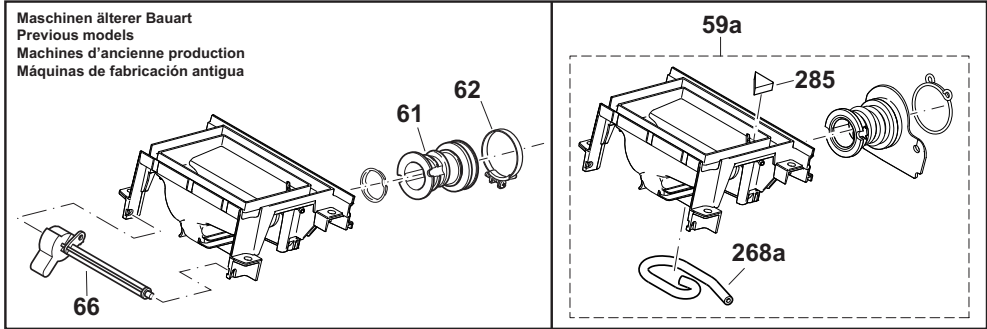

DPC6430, DPC6431, DPC7330, DPC7331, DPC8131,
DPC8132, DPC6440, DPC6441, DPC7340, DPC7341,
DPC6430, DPC7331, DPC8131, DPC8132, DPC6440
, DPC7341, DPC6430, DPC6431, DPC7330, DPC7331
, DPC8131, DPC8132, DPC6440, DPC6441,
DPC7340, DPC7341

3

Schalldämpfer
Muffler
Pot d' échappement
Silencioso



Seite / Page	Pos.	DPC6430	DPC6431	DPC7330	DPC7331	DPC8131	DPC8132	DPC6440	DPC6441	DPC7340	DPC7341	DPC6430 (UK)	DPC7331 (UK)	DPC8131 (UK)	DPC8132 (UK)	DPC6440 (UK)	DPC7341 (UK)	DPC6430 (USA)	DPC6431 (USA)	DPC7330 (USA)	DPC7331 (USA)	DPC8131 (USA)	DPC8132 (USA)	DPC6440 (USA)	DPC6441 (USA)	DPC7340 (USA)	DPC7341 (USA)	Teil-Nr. Part No. No. de pièce No. de pieza	Hinweise Notes Renseign. Nota	Bezeichnung	Spezifikation Specification	Description	Désignation	Denominación	
3	262							1	1	1	1																	394 174 550		SCHALLDÄMPFER	KAT	MUFFLER	POT D' ÉCHAPPEMENT	SILENCIADOR	
3	263							4	4	4	4																	908 005 095		SCHRAUBE	M5x9	SCREW	VIS	TORNILLO	
3	264							1	1	1	1																	394 174 340		FUNKENSCHUTZSIEB		SPARK ARRESTER SCREEN	TAMIS	TAMIZ	
3	266							1	1	1	1																	038 111 060		4KT-MUTTER	M5, SW10	SQUARE NUT	ECROU CARRÉ	TUERCA CUADR.	
3	268a	1	1	1	1	1	1	1	1	1	1	1	1	1	1	1	1	1	1	1	1	1	1	1	1	1	1	1	395 171 022		KOMPENSATIONS SCHLAUCH	l=155mm, black	TUBE	GAINE	TUBO
3	268b	1	1	1	1	1	1	1	1	1	1	1	1	1	1	1	1	1	1	1	1	1	1	1	1	1	1	395 171 024		KOMPENSATIONS SCHLAUCH	l=138mm, yellow	TUBE	GAINE	TUBO	
3	269	1	1	1	1	1	1	1	1	1	1	1	1	1	1	1	1	1	1	1	1	1	1	1	1	1	1	038 131 070		FEDERSCHELLE		HOSE CLIP	COLLIER DE SERRAGE	ABRAZADERA	
3	270	1	1	1	1	1	1	1	1	1	1	1	1	1	1	1	1	1	1	1	1	1	1	1	1	1	1	394 131 200		ANSAUGSCHLAUCH		SUCTION HOSE	TUYAU D' ASPIRATION	TUBO DE ASPIRACIÓN	
3	271	1	1	1	1	1	1	1	1	1	1	1	1	1	1	1	1	1	1	1	1	1	1	1	1	1	1	394 131 210		ANSAUGSCHLAUCH	SET	SUCTION HOSE	TUYAU D' ASPIRATION	TUBO DE ASPIRACIÓN	
3	272																	1	1	1	1	1						394 174 500		SCHALLDÄMPFER	USA, w/o KAT	EXHAUST MUFFLER	POT D' ÉCHAPPEMENT	SILENCIADOR	
3	285	1	1	1	1	1	1	1	1	1	1	1	1	1	1	1	1	1	1	1	1	1	1	1	1	1	1	395 173 030		SCHAUMSTOFFEINSATZ		FOAM-INSERT	MOUSSE DE NYLON	ESPUMA DE PLÁST.	

DPC6430, DPC6431, DPC7330, DPC7331, DPC8131,
 DPC8132, DPC6440, DPC6441, DPC7340, DPC7341,
 DPC6430, DPC7331, DPC8131, DPC8132, DPC6440
 , DPC7341 , DPC6430 , DPC6431 , DPC7330 , DPC7331
 , DPC8131 , DPC8132 , DPC6440 , DPC6441 ,
 DPC7340 , DPC7341

4

Vergaser
 Carburetor
 Carburateur
 Carburador

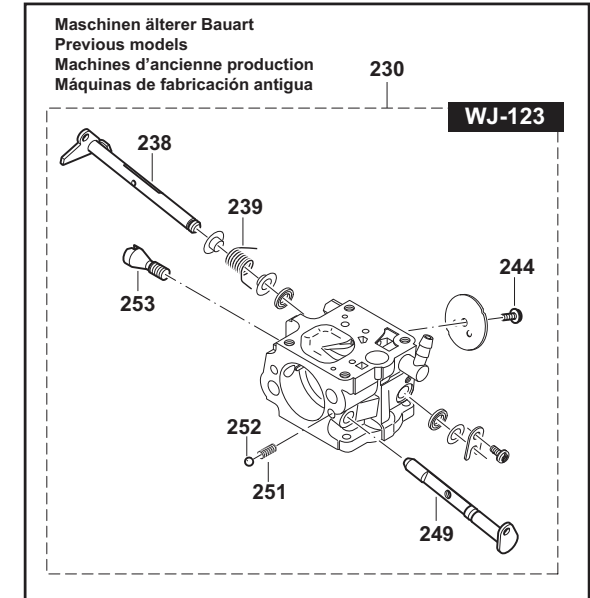
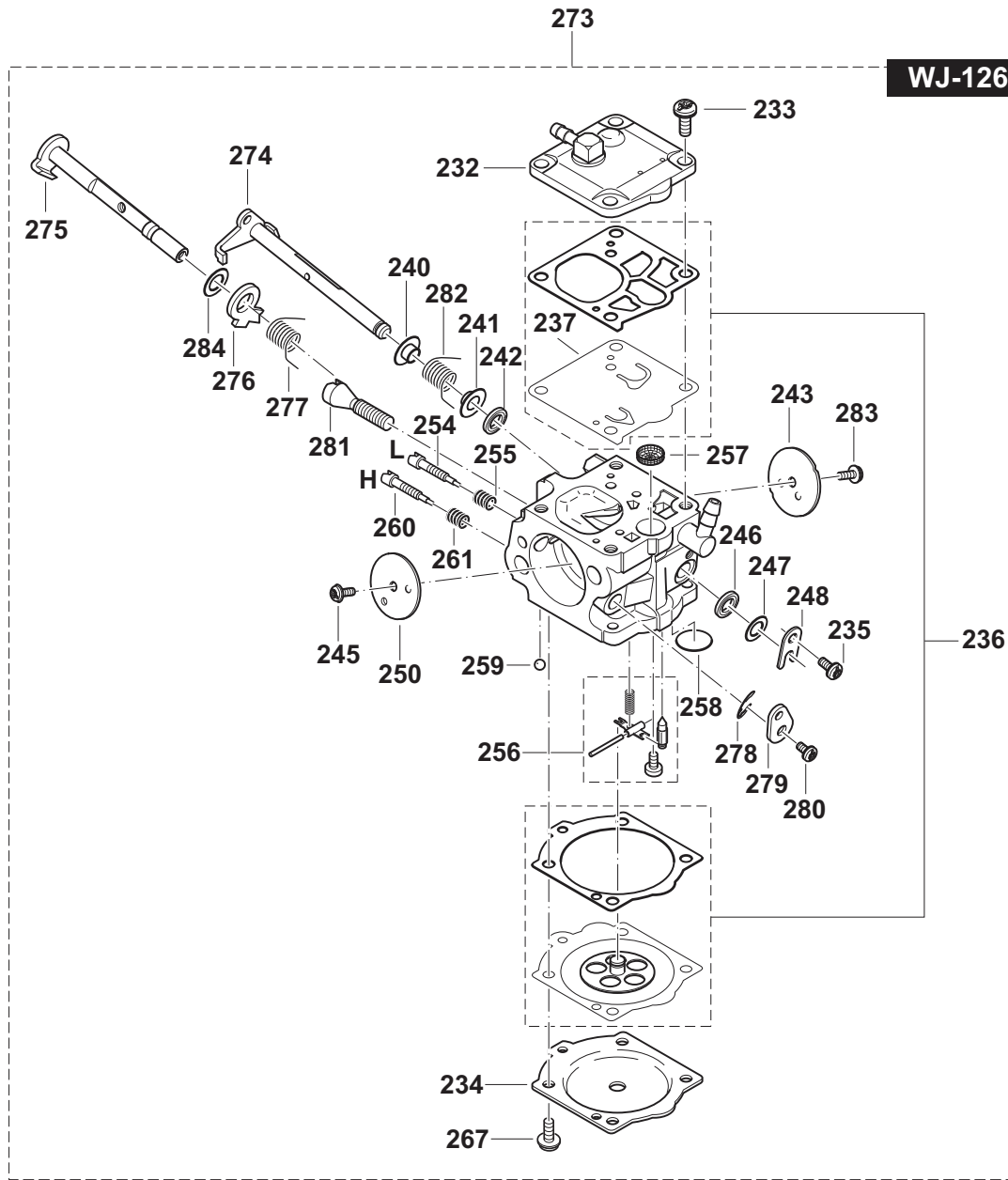

DPC6430, DPC6431, DPC7330, DPC7331, DPC8131, DPC8132, DPC6440, DPC6441, DPC7340, DPC7341, DPC6430, DPC7331, DPC8131, DPC8132, DPC6440, DPC7341, DPC6430, DPC6431, DPC7330, DPC7331, DPC8131, DPC8132, DPC6440, DPC6441, DPC7340, DPC7341

4

Vergaser
Carburetor
Carburateur
Carburador



Seite / Page	Pos.	DPC6430	DPC6431	DPC7330	DPC7331	DPC8131	DPC8132	DPC6440	DPC6441	DPC7340	DPC7341	DPC6430 (UK)	DPC7331 (UK)	DPC8131 (UK)	DPC8132 (UK)	DPC6440 (UK)	DPC7341 (UK)	DPC6430 (USA)	DPC6431 (USA)	DPC7330 (USA)	DPC7331 (USA)	DPC8131 (USA)	DPC8132 (USA)	DPC6440 (USA)	DPC6441 (USA)	DPC7340 (USA)	DPC7341 (USA)	Teil-Nr. Part No. No. de pièce No. de pieza	Hinweise Notes Renseign. Nota	Bezeichnung	Spezifikation Specification	Description	Désignation	Denominación	
4	230	1	1	1	1	1	1	1	1	1	1	1	1	1	1	1	1	1	1	1	1	1	1	1	1	1	1	1	395 151 050		VERGASER	WJ-123	CARBURETOR	CARBURATEUR	CARBURADOR
4	232	1	1	1	1	1	1	1	1	1	1	1	1	1	1	1	1	1	1	1	1	1	1	1	1	1	1	394 151 160		PUMPENDECKEL KPL.		PUMP COVER CPL.	COUVERCLE DE POMPE CPL.	TAPA DE BOMBA CPL.	
4	233	4	4	4	4	4	4	4	4	4	4	4	4	4	4	4	4	4	4	4	4	4	4	4	4	4	4	144 150 170		SCHRAUBE		SCREW	VIS	TORNILLO	
4	234	1	1	1	1	1	1	1	1	1	1	1	1	1	1	1	1	1	1	1	1	1	1	1	1	1	1	395 151 120		MEMBRANDECKEL		DIAPHRAGM COVER	COUVERCLE DE MEMBRANE	TAPA DE MEMBRANA	
4	235	1	1	1	1	1	1	1	1	1	1	1	1	1	1	1	1	1	1	1	1	1	1	1	1	1	1	378 151 220		SCHRAUBE		SCREW	VIS	TORNILLO	
4	236	1	1	1	1	1	1	1	1	1	1	1	1	1	1	1	1	1	1	1	1	1	1	1	1	1	1	957 151 180		MEMBRANSATZ		SET DIAPHRAGM / GASKETS	JEU DE MEMBRANES / JOINTS	JUEGO MEMBRANAS / JUNTAS	
4	237	1	1	1	1	1	1	1	1	1	1	1	1	1	1	1	1	1	1	1	1	1	1	1	1	1	1	394 151 150		PUMPENMEMBRA NE, GUMMI		PUMP DIAPHRAGM	MEMBR. DE POMPE	MEMBR. D. LA BOMBA	
4	238	1	1	1	1	1	1	1	1	1	1	1	1	1	1	1	1	1	1	1	1	1	1	1	1	1	1	394 151 300		DROSSELKLAPPE NWELLE		THROTTLE SHAFT	AXE CLAPET D' ÉTRANGLEM.	EJE VÁLVULA REGULADOR	
4	239	1	1	1	1	1	1	1	1	1	1	1	1	1	1	1	1	1	1	1	1	1	1	1	1	1	1	394 151 310		DREHFEDER		SPRING	RESSORT	RESORTE	
4	240	1	1	1	1	1	1	1	1	1	1	1	1	1	1	1	1	1	1	1	1	1	1	1	1	1	1	394 151 315		BUCHSE		BUSHING	DOUILLE	CASQUILLO	
4	241	1	1	1	1	1	1	1	1	1	1	1	1	1	1	1	1	1	1	1	1	1	1	1	1	1	1	394 151 315		BUCHSE		BUSHING	DOUILLE	CASQUILLO	
4	242	1	1	1	1	1	1	1	1	1	1	1	1	1	1	1	1	1	1	1	1	1	1	1	1	1	1	394 151 330		DICHTRING		PACKING RING	BAGUE-JOINT	ANILLO DE GUARNICIÓN	
4	243	1	1	1	1	1	1	1	1	1	1	1	1	1	1	1	1	1	1	1	1	1	1	1	1	1	1	394 151 320		DROSSELKLAPPE		THROTTLE SHUTTER	CLAPET D' ÉTRANGLEMEN T	VÁLVULA REGULADORA	
4	244	1	1	1	1	1	1	1	1	1	1	1	1	1	1	1	1	1	1	1	1	1	1	1	1	1	1	394 151 650		SCHRAUBE		SCREW	VIS	TORNILLO	
4	245	1	1	1	1	1	1	1	1	1	1	1	1	1	1	1	1	1	1	1	1	1	1	1	1	1	1	394 151 660		SCHRAUBE		SCREW	VIS	TORNILLO	
4	246	1	1	1	1	1	1	1	1	1	1	1	1	1	1	1	1	1	1	1	1	1	1	1	1	1	1	394 151 330		DICHTRING		PACKING RING	BAGUE-JOINT	ANILLO DE GUARNICIÓN	
4	247	1	1	1	1	1	1	1	1	1	1	1	1	1	1	1	1	1	1	1	1	1	1	1	1	1	1	394 151 400		SCHEIBE		DISC	DISQUE	DISCO	
4	248	1	1	1	1	1	1	1	1	1	1	1	1	1	1	1	1	1	1	1	1	1	1	1	1	1	1	108 151 350		WELLENSICHERU NG		SHAFT CLIP	TÔLE DE SÉCURITÉ	PIEZA SEGURIDAD ÁRBOL	
4	249	1	1	1	1	1	1	1	1	1	1	1	1	1	1	1	1	1	1	1	1	1	1	1	1	1	1	394 151 250		CHOKEWELLE		SHAFT	AXE	EJE	
4	250	1	1	1	1	1	1	1	1	1	1	1	1	1	1	1	1	1	1	1	1	1	1	1	1	1	1	395 151 260		CHOKEKLAPPE		CHOKE SHUTTER	CLAPET D' AIR	VÁLVULA DE AIRE	
4	251	1	1	1	1	1	1	1	1	1	1	1	1	1	1	1	1	1	1	1	1	1	1	1	1	1	1	118 151 160		ARRETIERFEDER		LOCKING SPRING	RESSORT D' ARRÊT	RESORTE DE TOPE	
4	252	1	1	1	1	1	1	1	1	1	1	1	1	1	1	1	1	1	1	1	1	1	1	1	1	1	1	118 151 170		ARRETIERKUGEL		LOCKING BALL	BILLE D' ARRÊT	BOLA DE TOPE	
4	253	1	1	1	1	1	1	1	1	1	1	1	1	1	1	1	1	1	1	1	1	1	1	1	1	1	1	394 151 570		LEERLAUF-ANSCH LAGSCHRAUBE	S	IDLE STOP SCREW	VIS DE BUTÉE DE RALENTI	TORNILLO DE TOPE	
4	254	1	1	1	1	1	1	1	1	1	1	1	1	1	1	1	1	1	1	1	1	1	1	1	1	1	1	394 151 470		LEERLAUF-STELLS CHRAUBE	L	IDLE ADJUSTMENT SCREW	VIS DE RÉGL. DE RALENTI	TORNILLO REGULADOR	
4	255	1	1	1	1	1	1	1	1	1	1	1	1	1	1	1	1	1	1	1	1	1	1	1	1	1	1	021 151 480		FEDER	L	SPRING	RESSORT	RESORTE	

DPC6430, DPC6431, DPC7330, DPC7331, DPC8131,
 DPC8132, DPC6440, DPC6441, DPC7340, DPC7341,
 DPC6430, DPC7331, DPC8131, DPC8132, DPC6440
 , DPC7341 , DPC6430 , DPC6431 , DPC7330 , DPC7331
 , DPC8131 , DPC8132 , DPC6440 , DPC6441 ,
 DPC7340 , DPC7341

4

Vergaser
 Carburetor
 Carburateur
 Carburador

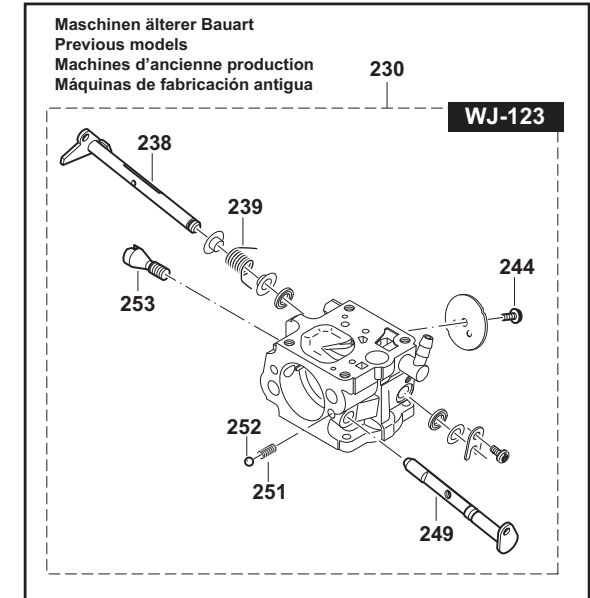
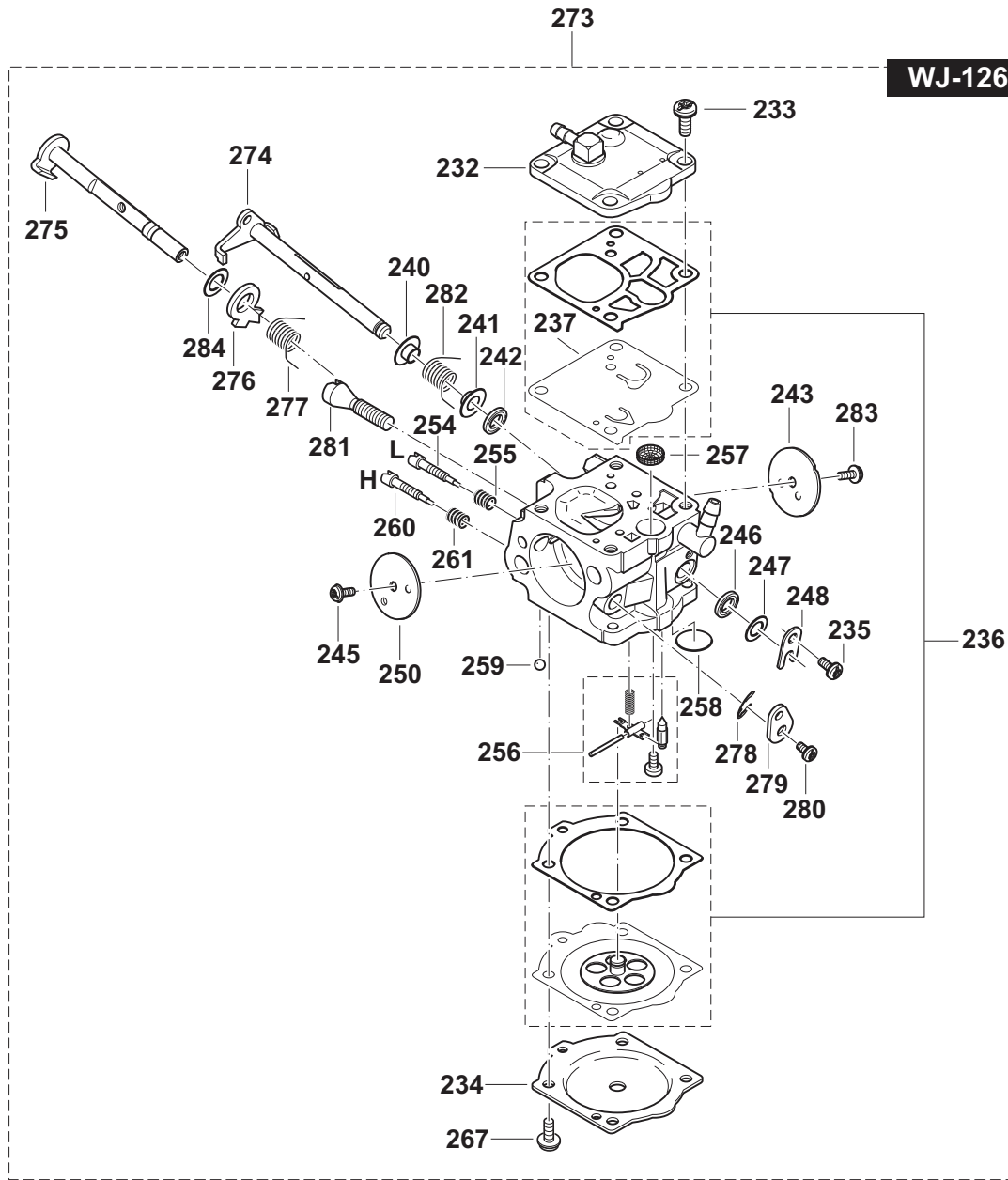

DPC6430, DPC6431, DPC7330, DPC7331, DPC8131, DPC8132, DPC6440, DPC6441, DPC7340, DPC7341, DPC6430, DPC7331, DPC8131, DPC8132, DPC6440, DPC7341, DPC6430, DPC6431, DPC7330, DPC7331, DPC8131, DPC8132, DPC6440, DPC6441, DPC7340, DPC7341

4

Vergaser
Carburetor
Carburateur
Carburador



Seite / Page	Pos.	DPC6430	DPC6431	DPC7330	DPC7331	DPC8131	DPC8132	DPC6440	DPC6441	DPC7340	DPC7341	DPC6430 (UK)	DPC7331 (UK)	DPC8131 (UK)	DPC8132 (UK)	DPC6440 (UK)	DPC7341 (UK)	DPC6430 (USA)	DPC6431 (USA)	DPC7330 (USA)	DPC7331 (USA)	DPC8131 (USA)	DPC8132 (USA)	DPC6440 (USA)	DPC6441 (USA)	DPC7340 (USA)	DPC7341 (USA)	Teil-Nr. Part No. No. de pièce No. de pieza	Hinweise Notes Renseign. Nota	Bezeichnung	Spezifikation Specification	Description	Désignation	Denominación		
4	256	1	1	1	1	1	1	1	1	1	1	1	1	1	1	1	1	1	1	1	1	1	1	1	1	1	1	957 151 191		SATZ STEUERTEILE		CONTROL PARTS		PIÈCES DE COMM.		PIEZAS DE MANDO
4	257	1	1	1	1	1	1	1	1	1	1	1	1	1	1	1	1	1	1	1	1	1	1	1	1	1	1	021 151 180		SIEB		SCREEN		TAMIS		TAMIZ
4	258	1	1	1	1	1	1	1	1	1	1	1	1	1	1	1	1	1	1	1	1	1	1	1	1	1	1	394 151 040		VERSCHLUßSCHEI BE		COVER DISC		DISQUE DE FERMETURE		DISCO DE SIERRE
4	259	1	1	1	1	1	1	1	1	1	1	1	1	1	1	1	1	1	1	1	1	1	1	1	1	1	1	394 151 510		SICHERUNGSEINS ATZ		LOCKING BALL		BILLE D' ARRÊT		BOLA DE TOPE
4	260	1	1	1	1	1	1	1	1	1	1	1	1	1	1	1	1	1	1	1	1	1	1	1	1	1	1	001 151 450		VOLLGAS-STELLS CHRAUBE	H	MAIN ADJUSTM. SCREW		VIS DE RÉGL. PLEIN GAZ		TORNILLO REGULADOR
4	261	1	1	1	1	1	1	1	1	1	1	1	1	1	1	1	1	1	1	1	1	1	1	1	1	1	1	021 151 480		FEDER	L	SPRING		RESSORT		RESORTE
4	267	4	4	4	4	4	4	4	4	4	4	4	4	4	4	4	4	4	4	4	4	4	4	4	4	4	4	378 151 220		SCHRAUBE		SCREW		VIS		TORNILLO
4	273	1	1	1	1	1	1	1	1	1	1	1	1	1	1	1	1	1	1	1	1	1	1	1	1	1	1	395 151 013		VERGASER HALBGAS	WJ-126a	CARBURETOR FAST IDLE		CARBURATEUR		CARBURADOR
4	274	1	1	1	1	1	1	1	1	1	1	1	1	1	1	1	1	1	1	1	1	1	1	1	1	1	1	395 151 130		DROSSELKLAPPE NWELLE		THROTTLE SHAFT		AXE CLAPET D ÉTRANG.		EJE VÁLVULA REG.
4	275	1	1	1	1	1	1	1	1	1	1	1	1	1	1	1	1	1	1	1	1	1	1	1	1	1	1	395 151 170		CHOKEWELLE		CHOKE SHAFT		AXE CLAPET D'AIR		EJE VÁLVULA AIRE
4	276	1	1	1	1	1	1	1	1	1	1	1	1	1	1	1	1	1	1	1	1	1	1	1	1	1	1	395 151 110		HALBGASHEBEL		FAST IDLE LEVER		LEVIER		PALANCA
4	277	1	1	1	1	1	1	1	1	1	1	1	1	1	1	1	1	1	1	1	1	1	1	1	1	1	1	395 151 190		DREHFEDER		TORSION SPRING		RESSORT DE TENSION		RESORTE DE TORSIÓN
4	278	1	1	1	1	1	1	1	1	1	1	1	1	1	1	1	1	1	1	1	1	1	1	1	1	1	1	119 151 350		WELLENSICHERU NG		SHAFT CLIP		TÔLE DE SÉCURITÉ		PIEZA SEGURIDAD ARBÓL
4	279	1	1	1	1	1	1	1	1	1	1	1	1	1	1	1	1	1	1	1	1	1	1	1	1	1	1	395 151 180		CHOKEHEBEL		CHOKE LEVER		LEVIER DE STARTER		PALANCA ESTRANGULADOR DE AIRE
4	280	1	1	1	1	1	1	1	1	1	1	1	1	1	1	1	1	1	1	1	1	1	1	1	1	1	1	394 151 660		SCHRAUBE		SCREW		VIS		TORNILLO
4	281	1	1	1	1	1	1	1	1	1	1	1	1	1	1	1	1	1	1	1	1	1	1	1	1	1	1	395 151 140		LEERLAUF-ANSCH LAGSCHRAUBE	S	IDLE STOP SCREW		VIS DE BUTÉE DE RALENTI		TORNILLO DE TOPE
4	282	1	1	1	1	1	1	1	1	1	1	1	1	1	1	1	1	1	1	1	1	1	1	1	1	1	1	395 151 150		DREHFEDER		TORSION SPRING		RESSORT DE TENSION		RESORTE DE TORSIÓN
4	283	1	1	1	1	1	1	1	1	1	1	1	1	1	1	1	1	1	1	1	1	1	1	1	1	1	1	170 151 250		SCHRAUBE		SCREW		VIS		TORNILLO
4	284	1	1	1	1	1	1	1	1	1	1	1	1	1	1	1	1	1	1	1	1	1	1	1	1	1	1	170 151 290		SCHEIBE		WASHER		RONDELLE		ARANDELA

DPC6430, DPC6431, DPC7330, DPC7331, DPC8131,
 DPC8132, DPC6440, DPC6441, DPC7340, DPC7341,
 DPC6430, DPC7331, DPC8131, DPC8132, DPC6440
 , DPC7341 , DPC6430 , DPC6431 , DPC7330 , DPC7331
 , DPC8131 , DPC8132 , DPC6440 , DPC6441 ,
 DPC7340 , DPC7341

5

Anwerfvorrichtung, Magnetzünder
 Starter Assy., ignition Assy.
 Dispositif de démarrage, volant magnétique
 Dispositivo arranque, volante magnético

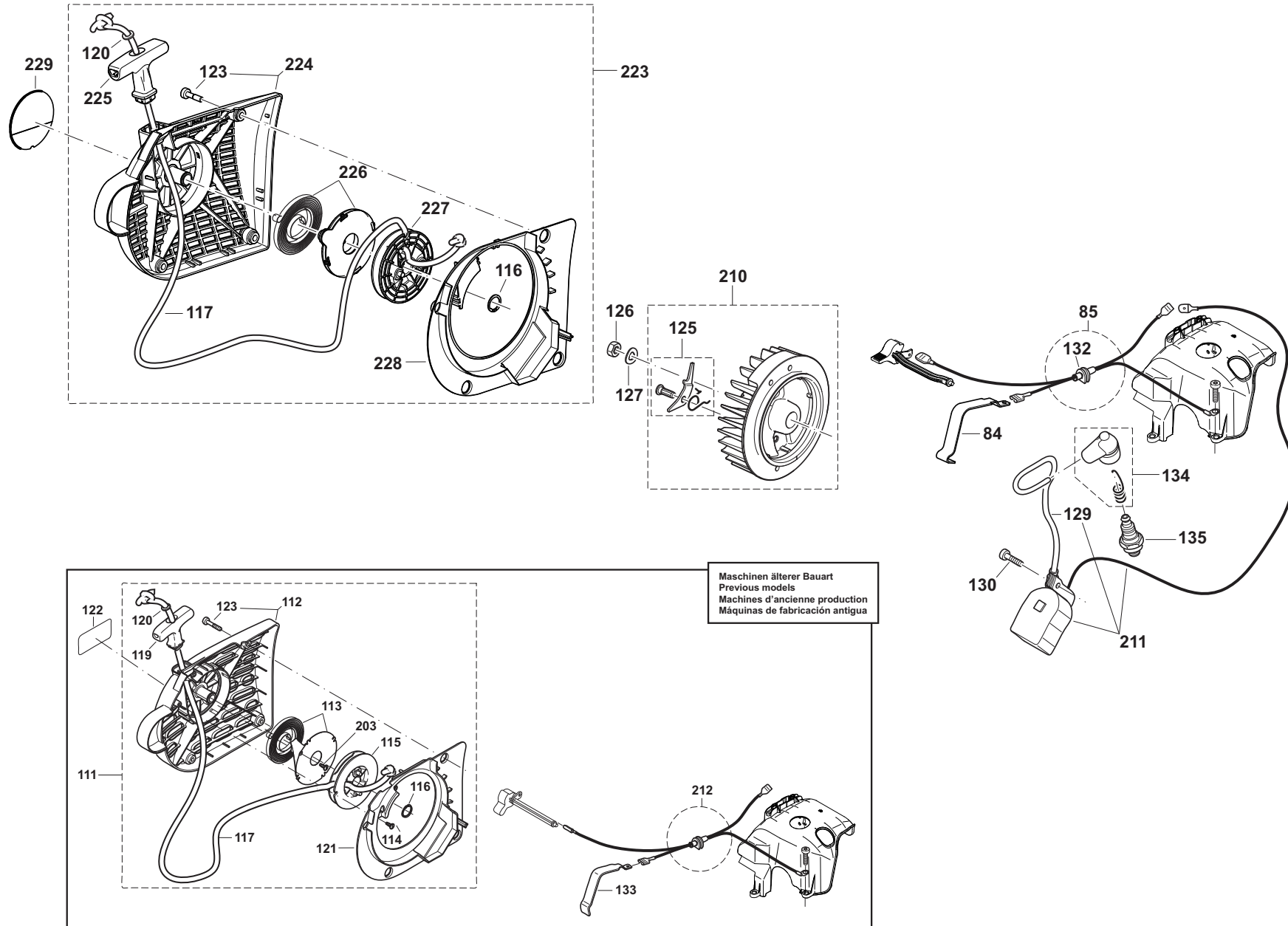

DPC6430, DPC6431, DPC7330, DPC7331, DPC8131,
 DPC8132, DPC6440, DPC6441, DPC7340, DPC7341,
 DPC6430, DPC7331, DPC8131, DPC8132, DPC6440
 , DPC7341 , DPC6430 , DPC6431 , DPC7330 , DPC7331
 , DPC8131 , DPC8132 , DPC6440 , DPC6441 ,
 DPC7340 , DPC7341

5

Anwerfvorrichtung, Magnetzünder
 Starter Assy., ignition Assy.
 Dispositif de démarrage, volant magnétique
 Dispositivo arranque, volante magnético

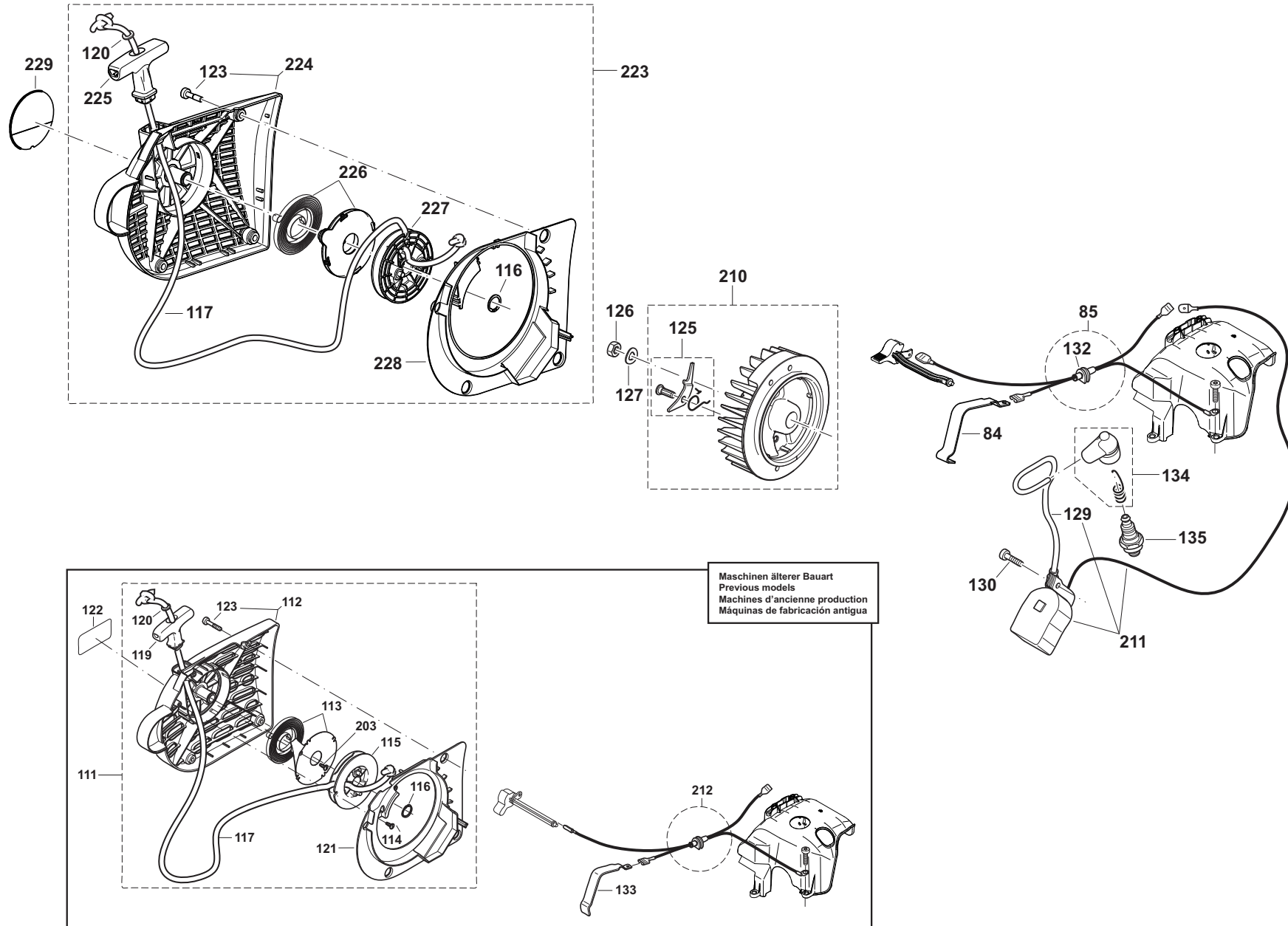

DPC6430, DPC6431, DPC7330, DPC7331, DPC8131,
DPC8132, DPC6440, DPC6441, DPC7340, DPC7341,
DPC6430, DPC7331, DPC8131, DPC8132, DPC6440
, DPC7341, DPC6430, DPC6431, DPC7330, DPC7331
, DPC8131, DPC8132, DPC6440, DPC6441,
DPC7340, DPC7341

6

Zylinder, Kurbeltrieb, Kupplung
Cylinder, crankshaft, clutch
Cylindre, vilebrequin, embrayage
Cilindro, cigüeñal, embrague

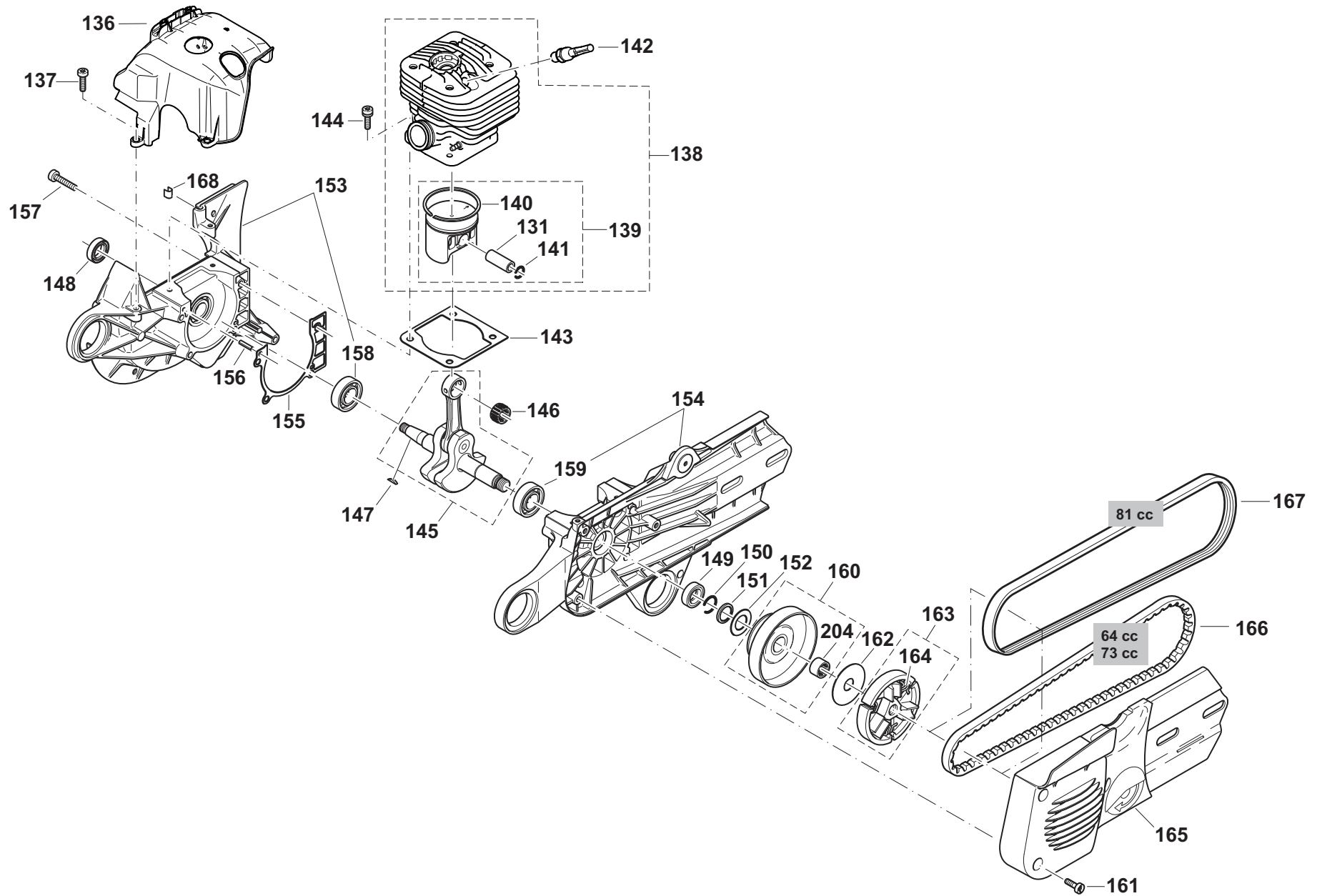

DPC6430, DPC6431, DPC7330, DPC7331, DPC8131, DPC8132, DPC6440, DPC6441, DPC7340, DPC7341, DPC6430, DPC7331, DPC8131, DPC8132, DPC6440, DPC7341, DPC6430, DPC6431, DPC7330, DPC7331, DPC8131, DPC8132, DPC6440, DPC6441, DPC7340, DPC7341

6

Zylinder, Kurbeltrieb, Kupplung
Cylinder, crankshaft, clutch
Cylindre, vilebrequin, embrayage
Cilindro, cigüeñal, embrague



Seite / Page	Pos.	DPC6430	DPC6431	DPC7330	DPC7331	DPC8131	DPC8132	DPC6440	DPC6441	DPC7340	DPC7341	DPC6430 (UK)	DPC7331 (UK)	DPC8131 (UK)	DPC8132 (UK)	DPC6440 (UK)	DPC7341 (UK)	DPC6430 (USA)	DPC6431 (USA)	DPC7330 (USA)	DPC7331 (USA)	DPC8131 (USA)	DPC8132 (USA)	DPC6440 (USA)	DPC6441 (USA)	DPC7340 (USA)	DPC7341 (USA)	Teil-Nr. Part No. No. de pièce No. de pieza	Hinweise Notes Renseign. Nota	Bezeichnung	Spezifikation Specification	Description	Désignation	Denominación	
6	131	1	1	1	1			1	1	1	1	1	1			1	1	1	1	1	1			1	1	1	1	1	119 132 030		KOLBENBOLZEN		PISTON PIN	AXE DE PISTON	PERNO DE PISTÓN
6	131					1	1							1	1													038 132 040		KOLBENBOLZEN		PISTON PIN	AXE DE PISTON	PERNO DE PISTÓN	
6	136	1	1	1	1	1	1	1	1	1	1	1	1	1	1	1	1	1	1	1	1	1	1	1	1	1	1	395 131 040		KÜHLLUFTHAUBE, SCHWARZ		HOOD	CAPOT	CUBIERTA	
6	137	3	3	3	3	3	3	3	3	3	3	3	3	3	3	3	3	3	3	3	3	3	3	3	3	3	3	909 005 155		SCHRAUBE	M5x15	BOLT	VIS	TORNILLO	
6	138	1	1					1	1							1	1											327 130 140		ZYLINDER / KOLBEN KPL.	ø 47 HeadDeco	CYLINDER / PISTON CPL.	CYLINDRE ET PISTON CPL.	CILINDRO CON PISTÓN CPL.	
6	138			1	1					1	1								1	1								395 130 140		ZYLINDER / KOLBEN KPL.	ø 50 HeadDeco	CYLINDER / PISTON CPL.	CYLINDRE ET PISTON CPL.	CILINDRO CON PISTÓN CPL.	
6	138					1	1							1	1													326 130 140		ZYLINDER / KOLBEN KPL.	ø 52 HeadDeco	CYLINDER / PISTON CPL.	CYLINDRE ET PISTON CPL.	CILINDRO CON PISTÓN CPL.	
6	139	1	1					1	1							1	1											325 132 034		KOLBEN KPL.	ø 47	PISTON CPL.	PISTON CPL.	PISTÓN CPL.	
6	139			1	1					1	1									1	1							395 132 050		KOLBEN KPL.	ø 50	PISTON CPL.	PISTON CPL.	PISTÓN CPL.	
6	139					1	1							1	1													038 132 002		KOLBEN AB KPL.	ø 52	PISTON CPL.	PISTON CPL.	PISTÓN CPL.	
6	140	1	1					1	1							1	1											325 132 050		KOLBENRING	ø 47	PISTON RING	SEGMENT DE PISTON	SEGMENTO DE PISTÓN	
6	140			1	1					1	1									1	1							394 132 020		KOLBENRING	ø 50	PISTON RING	SEGMENT DE PISTON	SEGMENTO DE PISTÓN	
6	140					1	1							1	1													038 132 020		KOLBENRING	ø 52	PISTON RING	SEGMENT DE PISTON	SEGMENTO DE PISTÓN	
6	141	2	2	2	2	2	2	2	2	2	2	2	2	2	2	2	2	2	2	2	2	2	2	2	2	2	2	119 132 060		SPRENGRING	C12X1	SPRING RING	ANNEAU-RESSORT	ANILLO ELÁSTICO	
6	142	1	1	1	1	1	1	1	1	1	1	1	1	1	1	1	1	1	1	1	1	1	1	1	1	1	1	395 118 071		DEKOMPRESSIONSVENTIL	HeadDeco	VALVE	SOUPAPE	VÁLVULA	
6	143	1	1	1	1	1	1	1	1	1	1	1	1	1	1	1	1	1	1	1	1	1	1	1	1	1	1	965 531 160		ZYLINDERFUßDICHTUNG, METALL		GASKET, METAL	JOINT, MÉTAL	JUNTA, METAL	
6	144	4	4	4	4	4	4	4	4	4	4	4	4	4	4	4	4	4	4	4	4	4	4	4	4	4	4	908 805 235		INNENSTERNSCHRAUBE MIT SPANNSCHEIBE	M5x23	SCREW	VIS	TORNILLO	
6	145	1	1	1	1			1	1	1	1	1	1			1	1	1	1	1	1							394 120 011		KURBELWELLE KPL.		CRANKSHAFT CPL.	VILEBREQUIN CPL.	CIGÜEÑAL CPL.	
6	145					1	1																					326 120 101		KURBELWELLE KPL.		CRANKSHAFT CPL.	VILEBREQUIN CPL.	CIGÜEÑAL CPL.	

DPC6430, DPC6431, DPC7330, DPC7331, DPC8131,
DPC8132, DPC6440, DPC6441, DPC7340, DPC7341,
DPC6430, DPC7331, DPC8131, DPC8132, DPC6440
, DPC7341, DPC6430, DPC6431, DPC7330, DPC7331
, DPC8131, DPC8132, DPC6440, DPC6441,
DPC7340, DPC7341

6

Zylinder, Kurbeltrieb, Kupplung
Cylinder, crankshaft, clutch
Cylindre, vilebrequin, embrayage
Cilindro, cigüeñal, embrague

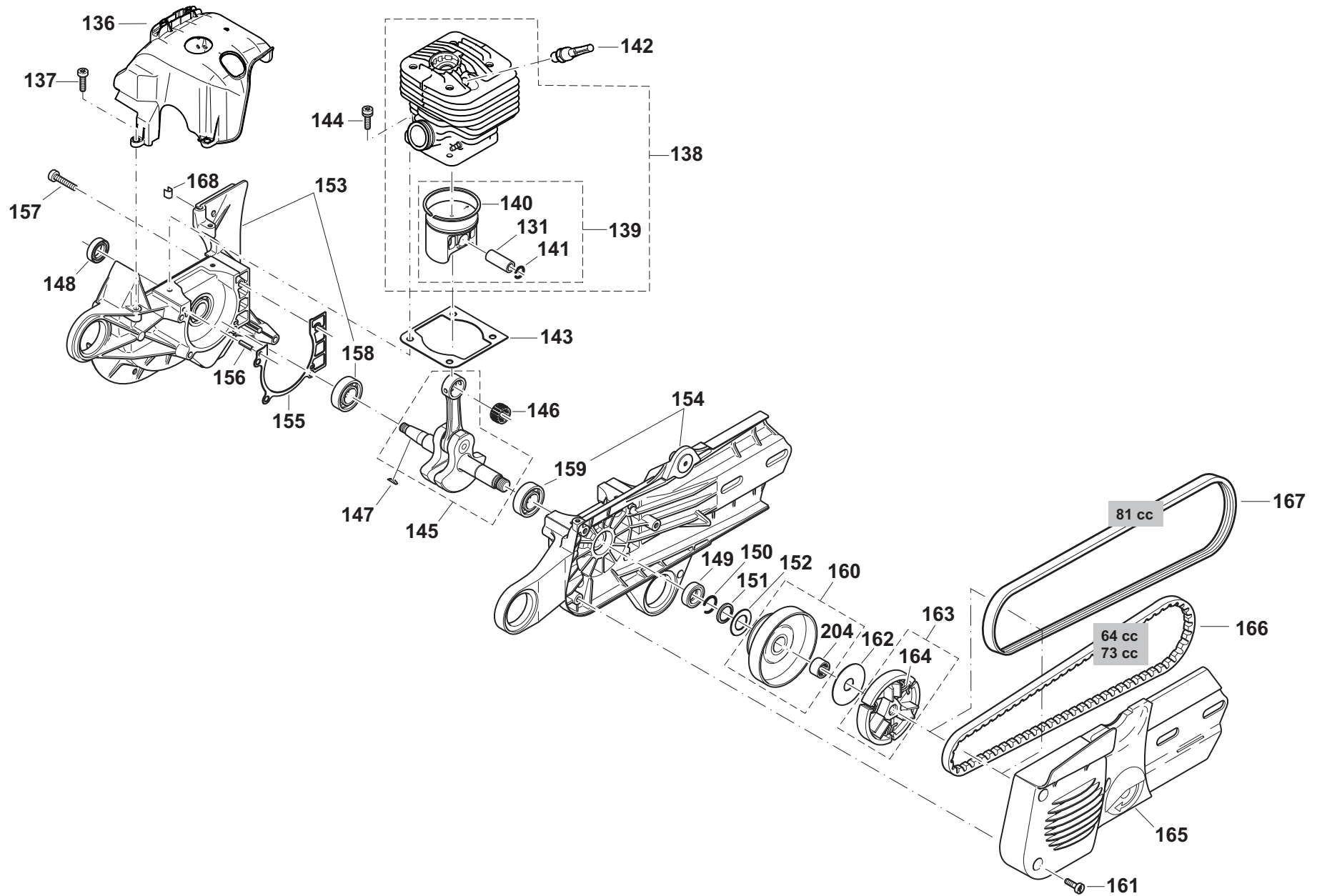

DPC6430, DPC6431, DPC7330, DPC7331, DPC8131, DPC8132, DPC6440, DPC6441, DPC7340, DPC7341, DPC6430, DPC7331, DPC8131, DPC8132, DPC6440, DPC7341, DPC6430, DPC6431, DPC7330, DPC7331, DPC8131, DPC8132, DPC6440, DPC6441, DPC7340, DPC7341

6

Zylinder, Kurbeltrieb, Kupplung
Cylinder, crankshaft, clutch
Cylindre, vilebrequin, embrayage
Cilindro, cigüeñal, embrague



Seite / Page	Pos.	DPC6430	DPC6431	DPC7330	DPC7331	DPC8131	DPC8132	DPC6440	DPC6441	DPC7340	DPC7341	DPC6430 (UK)	DPC7331 (UK)	DPC8131 (UK)	DPC8132 (UK)	DPC6440 (UK)	DPC7341 (UK)	DPC6430 (USA)	DPC6431 (USA)	DPC7330 (USA)	DPC7331 (USA)	DPC8131 (USA)	DPC8132 (USA)	DPC6440 (USA)	DPC6441 (USA)	DPC7340 (USA)	DPC7341 (USA)	Teil-Nr. Part No. No. de pièce No. de pieza	Hinweise Notes Renseign. Nota	Bezeichnung	Spezifikation Specification	Description	Désignation	Denominación	
6	146	1	1	1	1	1	1	1	1	1	1	1	1	1	1	1	1	1	1	1	1	1	1	1	1	1	1	1	962 210 121		NADELKRANZ		NEEDLE CAGE	CAGE À AIGUILLES	JAULA DE AGUJAS
6	147	1	1	1	1	1	1	1	1	1	1	1	1	1	1	1	1	1	1	1	1	1	1	1	1	1	1	1	939 630 370		SCHEIBENFEDER		KEY	CLAVETTE	CHAVETA
6	148	1	1	1	1	1	1	1	1	1	1	1	1	1	1	1	1	1	1	1	1	1	1	1	1	1	1	962 900 052		RADIALDICHTRING	ø15/24x7	RADIAL RING	JOINT RADIAL	JUNTA RADIAL	
6	149	1	1	1	1	1	1	1	1	1	1	1	1	1	1	1	1	1	1	1	1	1	1	1	1	1	1	962 900 052		RADIALDICHTRING	ø15/24x7	RADIAL RING	JOINT RADIAL	JUNTA RADIAL	
6	150	1	1	1	1	1	1	1	1	1	1	1	1	1	1	1	1	1	1	1	1	1	1	1	1	1	1	930 916 160		SPRENGRING		SPRING RING	ANNEAU-RESSORT	ANILLO ELÁSTICO	
6	151	1	1	1	1	1	1	1	1	1	1	1	1	1	1	1	1	1	1	1	1	1	1	1	1	1	1	394 245 010		ANSCHLAGRING, GEHÄRTET, VERZINKT		STOP RING	BAGUE DE BUTÉE	ANILLO DE DETEN.	
6	152	1	1	1	1	1	1	1	1	1	1	1	1	1	1	1	1	1	1	1	1	1	1	1	1	1	1	394 182 020		FÜHRUNGSSCHEIBE		GUIDE DISC	DISQUE DE GUIDAGE	DISCO DE GUÍA	
6	153	1	1	1	1	1	1	1	1	1	1	1	1	1	1	1	1	1	1	1	1	1	1	1	1	1	1	326 111 731		KURBELGEHÄUSE KPL. MS, SCHWARZ	incl. page 3: pos. 76,205,213	CRANKC., MAG. SIDE	CARTER-COTÉ, MAGN.	CÁRTER CIG., LADO MAG.	
6	154	1	1	1	1	1	1	1	1	1	1	1	1	1	1	1	1	1	1	1	1	1	1	1	1	1	1	326 111 740		KURBELGEHÄUSE KPL. KS, SCHWARZ		CRANKC., CLUTCH SIDE	CARTER-COTÉ, EMBR.	CÁRTER CIG., LADO EMBR.	
6	155	1	1	1	1	1	1	1	1	1	1	1	1	1	1	1	1	1	1	1	1	1	1	1	1	1	1	965 531 111		KURBELGEHÄUSEDICHTUNG		GASKET	JOINT	JUNTA	
6	156	2	2	2	2	2	2	2	2	2	2	2	2	2	2	2	2	2	2	2	2	2	2	2	2	2	2	936 430 160		SPIRALSPANNSTIFT	3X16	CLAMPING PIN	GOUPILLE	PASADOR	
6	157	5	5	5	5	5	5	5	5	5	5	5	5	5	5	5	5	5	5	5	5	5	5	5	5	5	5	908 005 305		INNENSTERN-SCHRAUBE	M5x30	SCREW	VIS	TORNILLO	
6	158	1	1	1	1	1	1	1	1	1	1	1	1	1	1	1	1	1	1	1	1	1	1	1	1	1	1	960 102 159		KUGELLAGER (EINKLEBEN)	6202	BALL BEARING (USE GLUE)	ROULEMENT À BILLES (À COLLER)	RODAM. DE BOLAS (A COLAR)	
6	159	1	1	1	1	1	1	1	1	1	1	1	1	1	1	1	1	1	1	1	1	1	1	1	1	1	1	960 102 159		KUGELLAGER (EINKLEBEN)	6202	BALL BEARING (USE GLUE)	ROULEMENT À BILLES (À COLLER)	RODAM. DE BOLAS (A COLAR)	
6	160	1	1	1	1	1	1	1	1	1	1	1	1	1	1	1	1	1	1	1	1	1	1	1	1	1	1	394 223 025		KUPPLUNGSTRÖMMEL KPL.		CLUTCH DRUM CPL.	TAMBOUR CPL.	TAMBOR CPL.	
6	160																											326 223 023		KUPPLUNGSTRÖMMEL KPL.	ø400mm-80m	CLUTCH DRUM CPL.	TAMBOUR CPL.	TAMBOR CPL.	
6	161	3	3	3	3	3	3	3	3	3	3	3	3	3	3	3	3	3	3	3	3	3	3	3	3	3	3	908 605 145		INNENSTERN-SCHRAUBE	M5x14	SCREW	VIS	TORNILLO	
6	162	1	1	1	1	1	1	1	1	1	1	1	1	1	1	1	1	1	1	1	1	1	1	1	1	1	1	001 182 042		FÜHRUNGSSCHEIBE	44,5x1x12	DISC	DISQUE	DISCO	

DPC6430, DPC6431, DPC7330, DPC7331, DPC8131,
DPC8132, DPC6440, DPC6441, DPC7340, DPC7341,
DPC6430, DPC7331, DPC8131, DPC8132, DPC6440
, DPC7341, DPC6430, DPC6431, DPC7330, DPC7331
, DPC8131, DPC8132, DPC6440, DPC6441,
DPC7340, DPC7341

6

Zylinder, Kurbeltrieb, Kupplung
Cylinder, crankshaft, clutch
Cylindre, vilebrequin, embrayage
Cilindro, cigüeñal, embrague

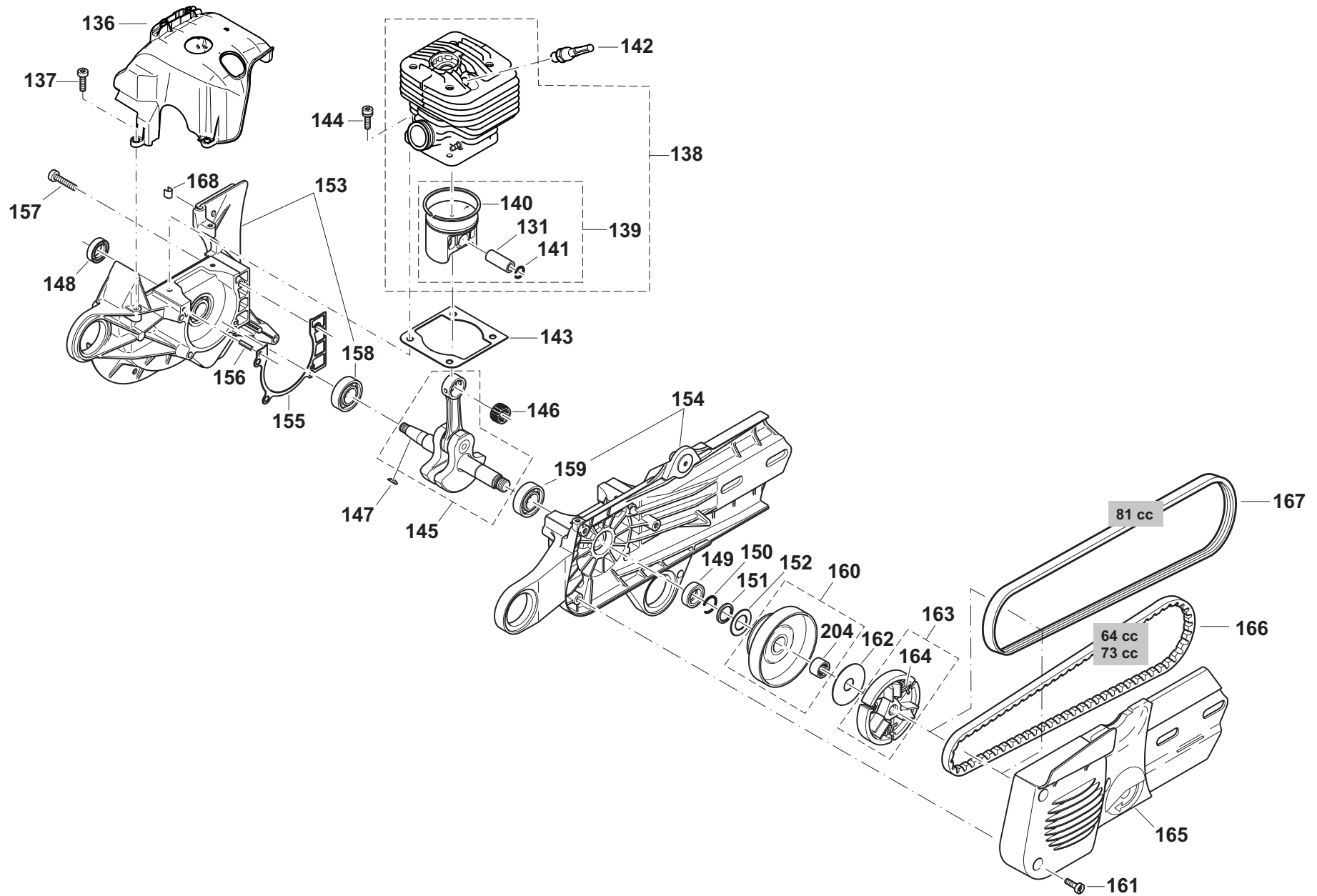

DPC6430, DPC6431, DPC7330, DPC7331, DPC8131, DPC8132, DPC6440, DPC6441, DPC7340, DPC7341, DPC6430, DPC7331, DPC8131, DPC8132, DPC6440, DPC7341, DPC6430, DPC6431, DPC7330, DPC7331, DPC8131, DPC8132, DPC6440, DPC6441, DPC7340, DPC7341

6

Zylinder, Kurbeltrieb, Kupplung
Cylinder, crankshaft, clutch
Cylindre, vilebrequin, embrayage
Cilindro, cigüeñal, embrague



Seite / Page	Pos.	DPC6430	DPC6431	DPC7330	DPC7331	DPC8131	DPC8132	DPC6440	DPC6441	DPC7340	DPC7341	DPC6430 (UK)	DPC7331 (UK)	DPC8131 (UK)	DPC8132 (UK)	DPC6440 (UK)	DPC7341 (UK)	DPC6430 (USA)	DPC6431 (USA)	DPC7330 (USA)	DPC7331 (USA)	DPC8131 (USA)	DPC8132 (USA)	DPC6440 (USA)	DPC6441 (USA)	DPC7340 (USA)	DPC7341 (USA)	Teil-Nr. Part No. No. de pièce No. de pieza	Hinweise Notes Renseign. Nota	Bezeichnung	Spezifikation Specification	Description	Désignation	Denominación
6	163	1	1	1	1	1	1	1	1	1	1	1	1	1	1	1	1	1	1	1	1	1	1	1	1	1	1	010 180 024		KUPPLUNG KPL.		CLUTCH ASSY.	EMBRAYAGE CPL.	EMBRAGUE CPL.
6	164	3	3	3	3	3	3	3	3	3	3	3	3	3	3	3	3	3	3	3	3	3	3	3	3	3	3	024 184 021		ZUGFEDER		SPRING	RESSORT	RESORTE
6	165	1	1	1	1	1	1	1	1	1	1		1	1	1		1	1	1	1	1	1	1	1	1	1	395 213 670	2010 =>	ABDECKUNG MIT SCHLITZEN, BLAU	blue, highly polished	COVER	COUVERCLE	CUBIERTA	
6	165	1	1	1	1	1	1	1	1	1	1		1	1	1		1	1	1	1	1	1	1	1	1	1	394 213 672		ABDECKUNG MIT SCHLITZEN, GRAU	grey	COVER	COUVERCLE	CUBIERTA	
6	165											1			1												395 213 680	U.K.	ABDECKUNG OHNE SCHLITZE, BLAU	blue, highly polished	COVER -DO NOT USE ON 73CCM MACHINES	COUVERCLE	CUBIERTA	
6	166	1	1	1	1			1	1	1	1	1	1			1	1	1	1	1				1	1	1	1	965 300 470		KEILRIEMEN		V-BELT	COURROIE TRAPEZ	CORREA ESTRECHO
6	167					1								1													965 300 481		KEILRIPPENRI EMEN	ø400mm-80m	V-BELT	COURROIE TRAPEZ	CORREA ESTRECHO	
6	167				1								1								1						965 300 490		KEILRIPPENRI EMEN	ø350mm-80m	V-BELT	COURROIE TRAPEZ	CORREA ESTRECHO	
6	168	1	1	1	1	1	1	1	1	1	1	1	1	1	1	1	1	1	1	1	1	1	1	1	1	1	965 402 870		FIXIERGUMMI	set=35 pcs.	RUBBER PLATE	PLAQUE DE CAOUTCH.	PLANCHA DE CAUCHO	
6	204	1	1	1	1	1	1	1	1	1	1	1	1	1	1	1	1	1	1	1	1	1	1	1	1	1	962 300 017		NADELHÜLSE		NEEDLE BUSH	ROULEMENT À AIGUILLES	JAULA DE AGUJAS	

DPC6430, DPC6431, DPC7330, DPC7331, DPC8131,
DPC8132, DPC6440, DPC6441, DPC7340, DPC7341,
DPC6430, DPC7331, DPC8131, DPC8132, DPC6440
, DPC7341, DPC6430, DPC6431, DPC7330, DPC7331
, DPC8131, DPC8132, DPC6440, DPC6441,
DPC7340, DPC7341

7

Schneidvorsatz, Schutzhaube
Cutting device, protection hood
Dispositif de coupe, capot de protection
Dispositivo tranzadora, cubierta protectora

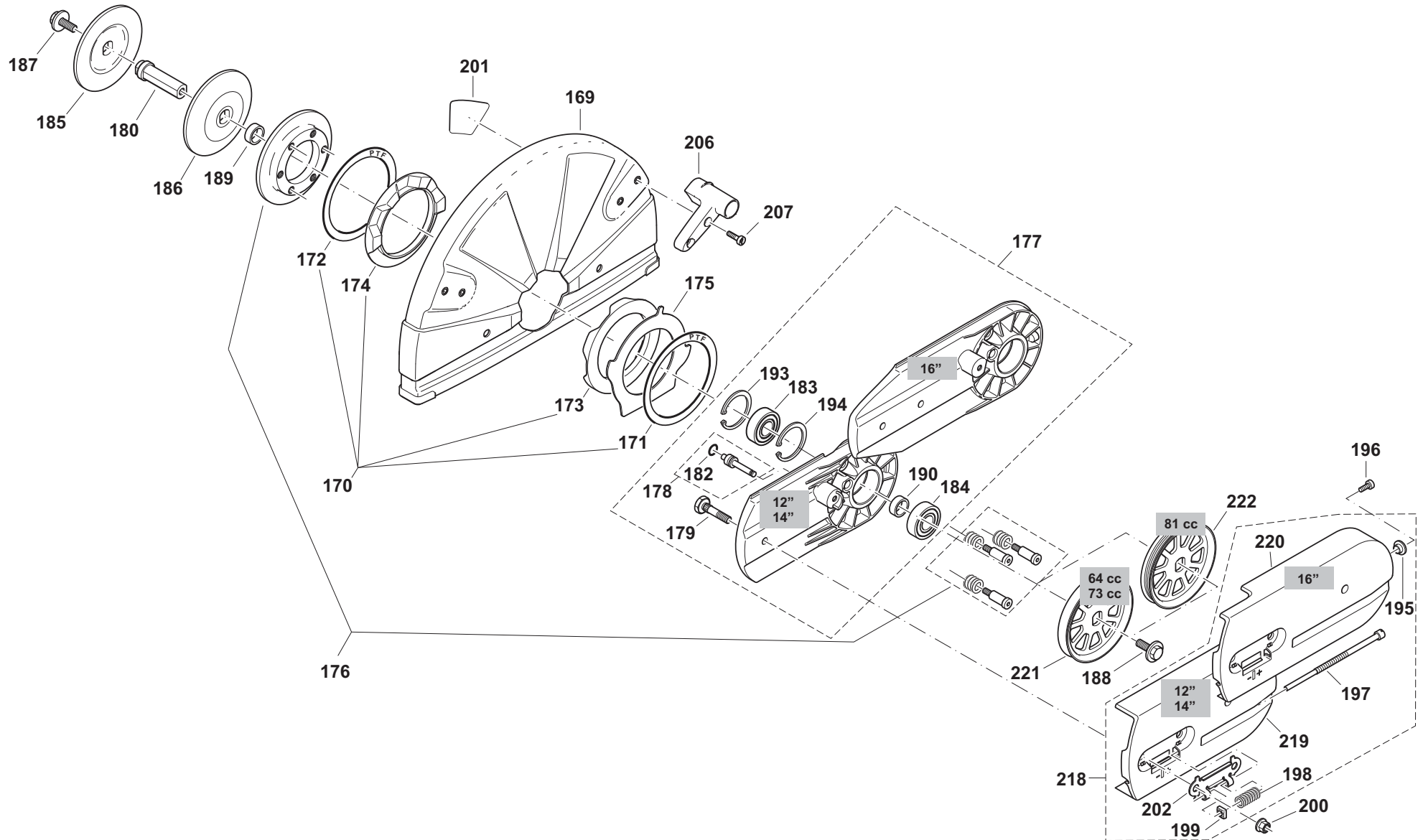

DPC6430, DPC6431, DPC7330, DPC7331, DPC8131, DPC8132, DPC6440, DPC6441, DPC7340, DPC7341, DPC6430, DPC7331, DPC8131, DPC8132, DPC6440, DPC7341, DPC6430, DPC6431, DPC7330, DPC7331, DPC8131, DPC8132, DPC6440, DPC6441, DPC7340, DPC7341

7

Schneidvorsatz, Schutzhaube
Cutting device, protection hood
Dispositif de coupe, capot de protection
Dispositivo tronzadora, cubierta protectora



Seite / Page	Pos.	DPC6430	DPC6431	DPC7330	DPC7331	DPC8131	DPC8132	DPC6440	DPC6441	DPC7340	DPC7341	DPC6430 (UK)	DPC7331 (UK)	DPC8131 (UK)	DPC8132 (UK)	DPC6440 (UK)	DPC7341 (UK)	DPC6430 (USA)	DPC6431 (USA)	DPC7330 (USA)	DPC7331 (USA)	DPC8131 (USA)	DPC8132 (USA)	DPC6440 (USA)	DPC6441 (USA)	DPC7340 (USA)	DPC7341 (USA)	Teil-Nr. Part No. No. de pièce No. de pieza	Hinweise Notes Renseign. Nota	Bezeichnung	Spezifikation Specification	Description	Désignation	Denominación
7	169	1		1				1		1		1				1	1		1								325 341 611		SCHUTZHAUBE, SILBER	ø 300mm; 12"	HOOD	CAPOT	CUBIERTA	
7	169		1		1	1				1		1	1					1	1	1	1					1	394 341 051		SCHUTZHAUBE, SILBER	ø 350mm; 14"	HOOD	CAPOT	CUBIERTA	
7	169						1							1									1				326 341 010		SCHUTZHAUBE, SILBER	ø 400mm; 16"	HOOD	CAPOT	CUBIERTA	
7	170	1	1	1	1	1	1	1	1	1	1	1	1	1	1	1	1	1	1	1	1	1	1	1	1	1	957 342 011		AUFNAHME SCHUTZHAUBE KPL.		PROT. HOOD MOUNTING, CPL.	LOGEMENT CAPOT DE PROT. CPL.	ALOJAMIENTO CUB. PROT., CPL.	
7	171	1	1	1	1	1	1	1	1	1	1	1	1	1	1	1	1	1	1	1	1	1	1	1	1	1	394 342 180		GLEITSCHLEIBE TEFLON		SLIDING DISC	DISQUE DE GLISSEMENT	ARANDELA DESLIZANTE	
7	172	1	1	1	1	1	1	1	1	1	1	1	1	1	1	1	1	1	1	1	1	1	1	1	1	1	394 342 180		GLEITSCHLEIBE TEFLON		SLIDING DISC	DISQUE DE GLISSEMENT	ARANDELA DESLIZANTE	
7	173	1	1	1	1	1	1	1	1	1	1	1	1	1	1	1	1	1	1	1	1	1	1	1	1	1	965 404 900		GUMMIRING AUßEN		RUBBER RING EXT.	BAGUE EN CAOUTCHOUC EXT.	ANILLO DE GOMA EXTERIOR	
7	174	1	1	1	1	1	1	1	1	1	1	1	1	1	1	1	1	1	1	1	1	1	1	1	1	1	965 404 920		GUMMIRING INNEN		RUBBER RING INT.	BAGUE EN CAOUTCHOUC INT.	ANILLO DE GOMA INTERIOR	
7	175	1	1	1	1	1	1	1	1	1	1	1	1	1	1	1	1	1	1	1	1	1	1	1	1	1	394 342 160		ANSCHLAGBLE CH		IMPACT PLATE	TÔLE DE BUTÉE	CHAPA DE TOPE	
7	176	1	1	1	1	1	1	1	1	1	1	1	1	1	1	1	1	1	1	1	1	1	1	1	1	1	394 342 211		DRUCKRING KPL., SCHWARZ		PRESSURE RING CPL.	BAGUE DE PRESSION CPL.	ANILLO DE PRESIÓN CPL.	
7	177	1	1	1	1	1		1	1	1	1	1	1	1	1	1	1	1	1	1	1		1	1	1	1	394 211 740		SCHNEIDVORS ATZ KPL., SCHWARZ		CUTTING DEVICE ASSY.	DISPOSITIF DE COUPE CPL.	DISPOS. TRANZADORA CPL.	
7	177					1								1								1					326 211 740		SCHNEIDVORS ATZ KPL., SCHWARZ		CUTTING DEVICE ASSY.	DISPOSITIF DE COUPE CPL.	DISPOS. TRANZADORA CPL.	
7	178	1	1	1	1	1	1	1	1	1	1	1	1	1	1	1	1	1	1	1	1	1	1	1	1	1	394 342 190		ANSCHLAGBOL ZEN KPL.		BOLT CPL.	BOULON CPL.	BULON CPL.	
7	179	2	2	2	2	2	2	2	2	2	2	2	2	2	2	2	2	2	2	2	2	2	2	2	2	2	394 211 091		BEFESTIGUNGS BOLZEN		TIGHTEN LOCKING BOLT	BOULON DE FIXATION	PERNO DE FIJACIÓN	
7	180	1	1	1	1	1	1	1	1	1	1	1	1	1	1	1	1	1	1	1	1	1	1	1	1	1	394 228 101		ACHSE	ø 20mm	AXLE	AXE	EJE	
7	180	1	1	1	1			1	1	1	1	1	1			1	1	1	1	1	1		1	1	1	1	394 228 130	Acc.	ACHSE	ø 22,2mm	AXLE	AXE	EJE	
7	180	1	1		1			1	1	1	1	1	1			1	1	1	1	1	1		1	1	1	1	394 228 111		ACHSE	ø 25,4mm; 1"	AXLE	AXE	EJE	
7	182	1	1	1	1	1	1	1	1	1	1	1	1	1	1	1	1	1	1	1	1	1	1	1	1	1	963 209 020		O-RING	9x2	PACKING RING	BAGUE-JOINT	ANILLO DE GUARNICIÓN	
7	183	1	1	1	1	1	1	1	1	1	1	1	1	1	1	1	1	1	1	1	1	1	1	1	1	1	960 102 176		KUGELLAGER		BALL BEARING	ROULEMENT À BILLES	RODAMIENTO DE BOLAS	

DPC6430, DPC6431, DPC7330, DPC7331, DPC8131, DPC8132, DPC6440, DPC6441, DPC7340, DPC7341, DPC6430, DPC7331, DPC8131, DPC8132, DPC6440, DPC7341, DPC6430, DPC6431, DPC7330, DPC7331, DPC8131, DPC8132, DPC6440, DPC6441, DPC7340, DPC7341

7

Schneidvorsatz, Schutzhaube
Cutting device, protection hood
Dispositif de coupe, capot de protection
Dispositivo tronzadora, cubierta protectora



Seite / Page	Pos.	DPC6430	DPC6431	DPC7330	DPC7331	DPC8131	DPC8132	DPC6440	DPC6441	DPC7340	DPC7341	DPC6430 (UK)	DPC7331 (UK)	DPC8131 (UK)	DPC8132 (UK)	DPC6440 (UK)	DPC7341 (UK)	DPC6430 (USA)	DPC6431 (USA)	DPC7330 (USA)	DPC7331 (USA)	DPC8131 (USA)	DPC8132 (USA)	DPC6440 (USA)	DPC6441 (USA)	DPC7340 (USA)	DPC7341 (USA)	Teil-Nr. Part No. No. de pièce No. de pieza	Hinweise Notes Renseign. Nota	Bezeichnung	Spezifikation Specification	Description	Désignation	Denominación
7	184	1	1	1	1	1	1	1	1	1	1	1	1	1	1	1	1	1	1	1	1	1	1	1	1	1	1	960 102 176		KUGELLAGER		BALL BEARING	ROULEMENT À BILLES	RODAMIENTO DE BOLAS
7	185	1	1	1	1	1	1	1	1	1	1	1	1	1	1	1	1	1	1	1	1	1	1	1	1	1	326 228 020		SPANNFLANSCH	12"-16"	PRESSURE DISC	DISQUE DE PRESSION	DISCO DE PRESIÓN	
7	186	1	1	1	1	1	1	1	1	1	1	1	1	1	1	1	1	1	1	1	1	1	1	1	1	1	326 228 020		SPANNFLANSCH	12"-16"	PRESSURE DISC	DISQUE DE PRESSION	DISCO DE PRESIÓN	
7	187	1	1	1	1	1	1	1	1	1	1	1	1	1	1	1	1	1	1	1	1	1	1	1	1	1	994 280 250		6KT-SCHRAUBE	M8x25	HEXAGONAL SCREW	VIS HEXAGONAL	TORNILLO HEXAGONAL	
7	188	1	1	1	1	1	1	1	1	1	1	1	1	1	1	1	1	1	1	1	1	1	1	1	1	1	994 280 250		6KT-SCHRAUBE	M8x25	HEXAGONAL SCREW	VIS HEXAGONAL	TORNILLO HEXAGONAL	
7	189	1	1	1	1	1	1	1	1	1	1	1	1	1	1	1	1	1	1	1	1	1	1	1	1	1	394 228 021		DISTANZHÜLSE		SPACER	DOUILLE DE DISTANCE	CASQUILLO SEPARADOR	
7	190	1	1	1	1	1	1	1	1	1	1	1	1	1	1	1	1	1	1	1	1	1	1	1	1	1	394 228 021		DISTANZHÜLSE		SPACER	DOUILLE DE DISTANCE	CASQUILLO SEPARADOR	
7	193	1	1	1	1	1	1	1	1	1	1	1	1	1	1	1	1	1	1	1	1	1	1	1	1	1	929 240 180		SICHERUNGSRING		SNAP RING	CIRCLIP	ANILLO SEGURIDAD	
7	194	1	1	1	1	1	1	1	1	1	1	1	1	1	1	1	1	1	1	1	1	1	1	1	1	1	929 240 180		SICHERUNGSRING		SNAP RING	CIRCLIP	ANILLO SEGURIDAD	
7	195													1													326 211 020		BUCHSE		BUSHING	DOUILLE	CASQUILLO	
7	196						1							1													908 905 125		INNEN-6KT-SCHRAUBE	5x12	SCREW	VIS	TORNILLO	
7	197	1	1	1	1	1	1	1	1	1	1	1	1	1	1	1	1	1	1	1	1	1	1	1	1	1	394 213 032		SPANNSCHRAUBE		TENSIONING SCREW	VIS DE TENSION	TORNILLO DE TENSIÓN	
7	198	1	1	1	1	1	1	1	1	1	1	1	1	1	1	1	1	1	1	1	1	1	1	1	1	1	394 342 120		DRUCKFEDER		SPRING	RESSORT	RESORTE	
7	199	1	1	1	1	1	1	1	1	1	1	1	1	1	1	1	1	1	1	1	1	1	1	1	1	1	921 906 004		4KT-MUTTER	M6	SQUARE NUT	ECROU CARRÉ	TUERCA CUADR.	
7	200	2	2	2	2	2	2	2	2	2	2	2	2	2	2	2	2	2	2	2	2	2	2	2	2	2	923 208 004		6KT-MUTTER	M8	HAXAGONAL NUT	ECROU HEXAGONAL	TUERCA HEXAGONAL	
7	201	1		1				1						1													980 114 972		SICHERHEITSAUFKLEBER	ø300/20,0mm; ø12"/.787"	SAFETY LABEL	PLAQUE	CALCOMANIA	
7	201	1		1																							980 115 616	RU	SICHERHEITSAUFKLEBER	ø300/20,0mm; ø12"/.787"	SAFETY LABEL	PLAQUE	CALCOMANIA	
7	201	1									1																980 115 557		SICHERHEITSAUFKLEBER	ø300/25,4mm; ø12"/1"	SAFETY LABEL	PLAQUE	CALCOMANIA	
7	201		1		1					1																	980 114 974		SICHERHEITSAUFKLEBER	ø350/20,0mm; ø14"/.787"	SAFETY LABEL	PLAQUE	CALCOMANIA	
7	201		1		1	1				1																	980 114 975		SICHERHEITSAUFKLEBER	ø350/25,4mm; ø14"/1"	SAFETY LABEL	PLAQUE	CALCOMANIA	
7	201		1		1																						980 115 614	RU	SICHERHEITSAUFKLEBER	ø350/25,4mm; ø14"/1"	SAFETY LABEL	PLAQUE	CALCOMANIA	
7	201					1																					980 115 226		SICHERHEITSAUFKLEBER	ø400/20,0mm; ø16"/.787"	SAFETY LABEL	PLAQUE	CALCOMANIA	

DPC6430, DPC6431, DPC7330, DPC7331, DPC8131,
 DPC8132, DPC6440, DPC6441, DPC7340, DPC7341,
 DPC6430, DPC7331, DPC8131, DPC8132, DPC6440
 , DPC7341, DPC6430, DPC6431, DPC7330, DPC7331
 , DPC8131, DPC8132, DPC6440, DPC6441,
 DPC7340, DPC7341

7

Schneidvorsatz, Schutzhaube
 Cutting device, protection hood
 Dispositif de coupe, capot de protection
 Dispositivo tranzadora, cubierta protectora

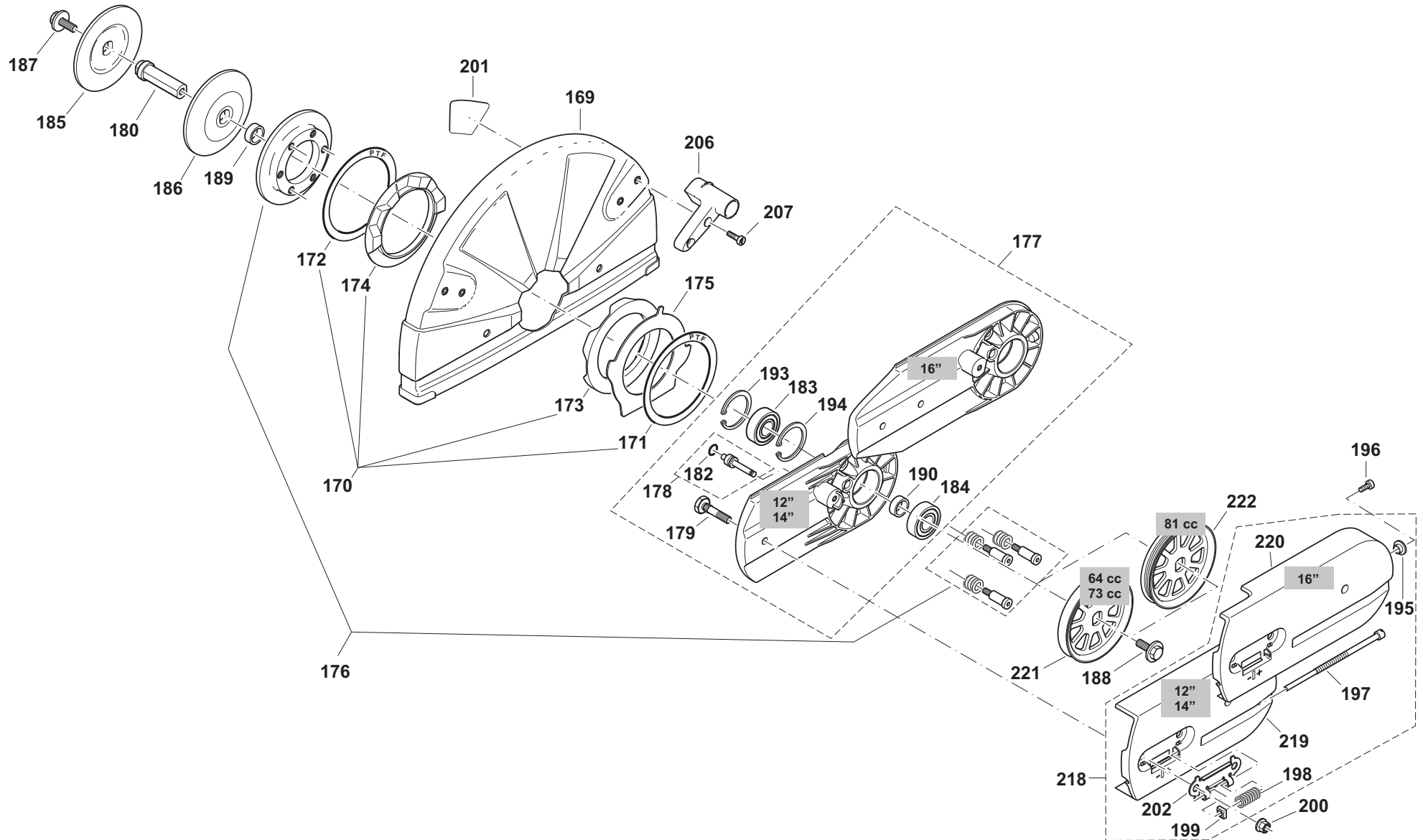

DPC6430, DPC6431, DPC7330, DPC7331, DPC8131, DPC8132, DPC6440, DPC6441, DPC7340, DPC7341, DPC6430, DPC7331, DPC8131, DPC8132, DPC6440, DPC7341, DPC6430, DPC6431, DPC7330, DPC7331, DPC8131, DPC8132, DPC6440, DPC6441, DPC7340, DPC7341

7

Schneidvorsatz, Schutzhaube
Cutting device, protection hood
Dispositif de coupe, capot de protection
Dispositivo tranzadora, cubierta protectora



Seite / Page	Pos.	DPC6430	DPC6431	DPC7330	DPC7331	DPC8131	DPC8132	DPC6440	DPC6441	DPC7340	DPC7341	DPC6430 (UK)	DPC7331 (UK)	DPC8131 (UK)	DPC8132 (UK)	DPC6440 (UK)	DPC7341 (UK)	DPC6430 (USA)	DPC6431 (USA)	DPC7330 (USA)	DPC7331 (USA)	DPC8131 (USA)	DPC8132 (USA)	DPC6440 (USA)	DPC6441 (USA)	DPC7340 (USA)	DPC7341 (USA)	Teil-Nr. Part No. No. de pièce No. de pieza	Hinweise Notes Renseign. Nota	Bezeichnung	Spezifikation Specification	Description	Désignation	Denominación
7	201					1																					980 115 612	RU	SICHERHEITSAUFKLEBER	ø400/20,0mm; ø16"/.787"	SAFETY LABEL	PLAQUE	CALCOMANIA	
7	202	1	1	1	1	1	1	1	1	1	1	1	1	1	1	1	1	1	1	1	1	1	1	1	1	1	1	394 213 021		AUFNAHMEBLECH		METAL SHEET	TÔLE	CHAPA
7	206	1	1	1	1	1	1	1	1	1	1	1	1	1	1	1	1	1	1	1	1	1	1	1	1	1	326 341 300		GRIF FÜR SCHUTZHAUBE		GRIP	POIGNÉE	ASA	
7	207	2	2	2	2	2	2	2	2	2	2	2	2	2	2	2	2	2	2	2	2	2	2	2	2	2	2	908 605 165		INNENSTERN-SCHLITZ-SCHRAUBE	M5x16	SCREW	VIS	TORNILLO
7	218	1	1	1	1	1	1	1	1	1	1	1	1	1	1	1	1	1	1	1	1	1	1	1	1	1	395 211 640	2010 =>	ABDECKUNG SCHNEIDVORS. KPL., BLAU	14", blue, highly polished	COVER CPL.	COUVERCLE CPL.	CUBIERTA CPL.	
7	218					1								1									1				395 211 650	2010 =>	ABDECKUNG SCHNEIDVORS. KPL., BLAU	16", blue, highly polished	COVER CPL.	COUVERCLE CPL.	CUBIERTA CPL.	
7	219	1	1	1	1	1	1	1	1	1	1	1	1	1	1	1	1	1	1	1	1	1	1	1	1	1	395 211 620	2010 =>	ABDECKUNG SCHNEIDVORS. , BLAU	14", blue, highly polished	COVER	COUVERCLE	CUBIERTA	
7	220					1								1									1				395 211 630	2010 =>	ABDECKUNG SCHNEIDVORS. , BLAU	16", blue, highly polished	COVER	COUVERCLE	CUBIERTA	
7	220					1								1									1				326 211 611		ABDECKUNG SCHNEIDVORS ATZ	16", grey	COVER	COUVERCLE	CUBIERTA	
7	221	1	1	1	1			1	1	1	1	1	1										1	1	1	1	394 221 050		KEILRIEMENSCHHEIBE		BELT PULLEY	POULIE	POLEA	
7	222					1	1							1	1												326 221 020		KEILRIPPENSCHHEIBE		BELT PULLEY	POULIE	POLEA	

DPC6430, DPC6431, DPC7330, DPC7331, DPC8131,
DPC8132, DPC6440, DPC6441, DPC7340, DPC7341,
DPC6430, DPC7331, DPC8131, DPC8132, DPC6440
, DPC7341, DPC6430, DPC6431, DPC7330, DPC7331
, DPC8131, DPC8132, DPC6440, DPC6441,
DPC7340, DPC7341

8

Trennscheiben, Werkzeug
Blades, tools
Disques, outils
Discos para dividir, herramientas

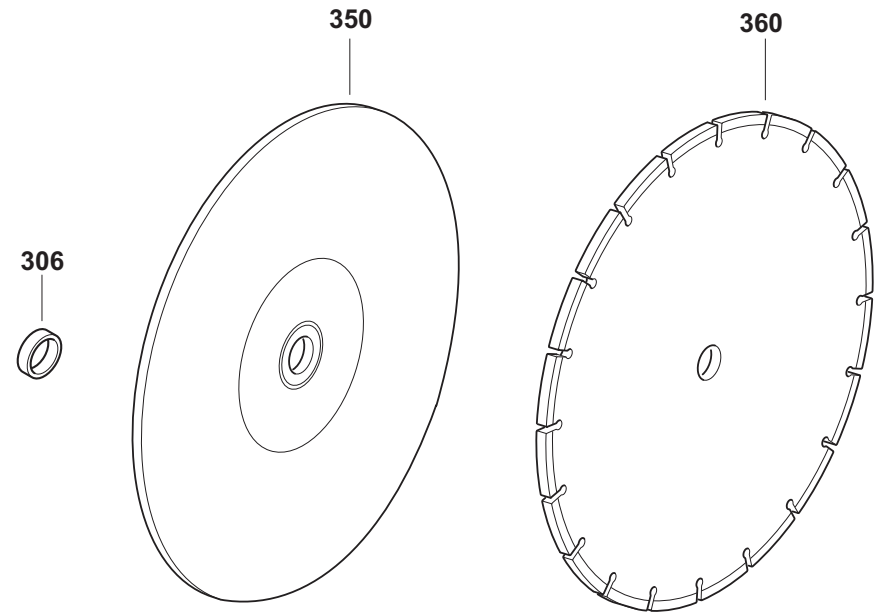
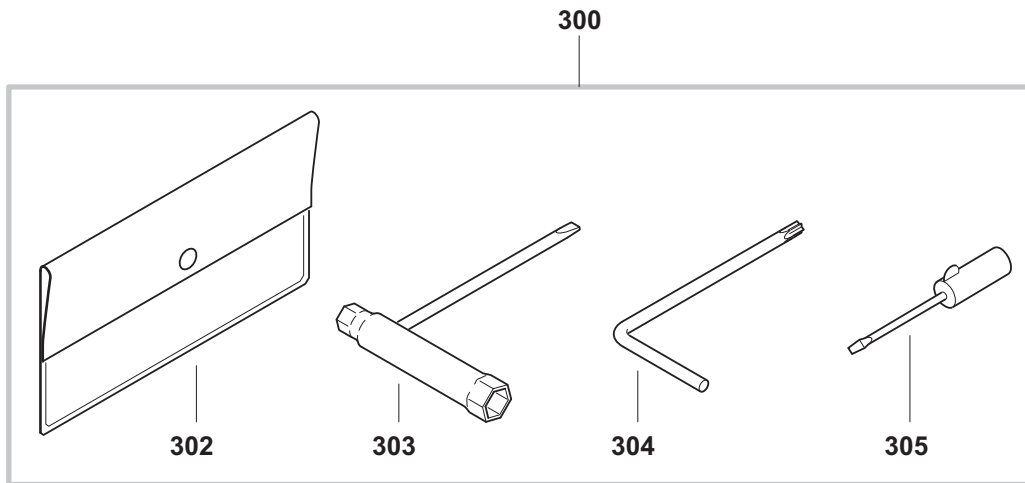

DPC6430, DPC6431, DPC7330, DPC7331, DPC8131, DPC8132, DPC6440, DPC6441, DPC7340, DPC7341, DPC6430, DPC7331, DPC8131, DPC8132, DPC6440, DPC7341, DPC6430, DPC6431, DPC7330, DPC7331, DPC8131, DPC8132, DPC6440, DPC6441, DPC7340, DPC7341

8

Trennscheiben, Werkzeug
Blades, tools
Disques, outils
Discos para dividir, herramientas



Seite / Page	Pos.	DPC6430	DPC6431	DPC7330	DPC7331	DPC8131	DPC8132	DPC6440	DPC6441	DPC7340	DPC7341	DPC6430 (UK)	DPC7331 (UK)	DPC8131 (UK)	DPC8132 (UK)	DPC6440 (UK)	DPC7341 (UK)	DPC6430 (USA)	DPC6431 (USA)	DPC7330 (USA)	DPC7331 (USA)	DPC8131 (USA)	DPC8132 (USA)	DPC6440 (USA)	DPC6441 (USA)	DPC7340 (USA)	DPC7341 (USA)	Teil-Nr. Part No. No. de pièce No. de pieza	Hinweise Notes Renseign. Nota	Bezeichnung	Spezifikation Specification	Description	Désignation	Denominación
8	300	1	1	1	1	1	1	1	1	1	1	1	1	1	1	1	1	1	1	1	1	1	1	1	1	1	1	957 004 006		WERKZEUG KPL.		TOOLS CPL.	OUTILS CPL.	HERRAMIENTAS CPL.
8	302	1	1	1	1	1	1	1	1	1	1	1	1	1	1	1	1	1	1	1	1	1	1	1	1	1	1	950 004 002		WERKZEUGTAS CHE		PLASTIK BAG	POCHETTE EN PLASTIQUE	CÁRTERA HERRAMIENTAS
8	303	1	1	1	1	1	1	1	1	1	1	1	1	1	1	1	1	1	1	1	1	1	1	1	1	1	1	941 719 140		KOMBISCHLÜS SEL	SW 13/19	UNIVERSAL WRENCH	CLÉ COMBINÉE	LLAVE DE BUJIA
8	304	1	1	1	1	1	1	1	1	1	1	1	1	1	1	1	1	1	1	1	1	1	1	1	1	1	1	940 827 000		WINKELSCHRA UBENDREHER	T27	ANGLED SCREW DRIVER	CLÉ ANGLE	LLAVE ANGULAR
8	305	1	1	1	1	1	1	1	1	1	1	1	1	1	1	1	1	1	1	1	1	1	1	1	1	1	1	944 340 001		SCHRAUBEND REHER		SCREWDRIVER	TOURNEVIS	DESTORNILLAD OR
8	306	1	1	1	1	1	1	1	1	1	1	1	1	1	1	1	1	1	1	1	1	1	1	1	1	1	1	394 228 121	Acc.	ADAPTERRING	ø 20/25,4 mm	ADAPTER	ADAPTATEUR	ADAPTOR
8	350	1	1	1	1	1	1	1	1	1	1	1	1	1	1	1	1	1	1	1	1	1	1	1	1	1	1	966 121 151		TRENNSCH. HARZ, STAHL	300/20mm; 12"	ABRAS. BLADE, STEEL	DISQUE SYNTH. ACIER	DISCO SINT. ACERO
8	350	1	1	1	1	1	1	1	1	1	1	1	1	1	1	1	1	1	1	1	1	1	1	1	1	1	1	966 121 120		TRENNSCH. HARZ, STEIN	300/20mm; 12"	ABRAS. BLADE, STONE	DISQUE SYNTH. BÉTON	DISCO SINT. PEDRA
8	350	1	1	1	1	1	1	1	1	1	1	1	1	1	1	1	1	1	1	1	1	1	1	1	1	1	1	966 144 151		TRENNSCH. HARZ, STAHL	350/25,4mm; 14"	ABRAS. BLADE, STEEL	DISQUE SYNTH. ACIER	DISCO SINT. ACERO
8	350	1	1	1	1	1	1	1	1	1	1	1	1	1	1	1	1	1	1	1	1	1	1	1	1	1	1	966 144 120		TRENNSCH. HARZ, STEIN	350/25,4mm; 14"	ABRAS. BLADE, STONE	DISQUE SYNTH. BÉTON	DISCO SINT. PEDRA
8	350	1	1	1	1	1	1	1	1	1	1	1	1	1	1	1	1	1	1	1	1	1	1	1	1	1	1	966 141 150		TRENNSCH. HARZ, STAHL	350/20mm; 14"	ABRAS. BLADE, STEEL	DISQUE SYNTH. ACIER	DISCO SINT. ACERO
8	350	1	1	1	1	1	1	1	1	1	1	1	1	1	1	1	1	1	1	1	1	1	1	1	1	1	1	966 141 120		TRENNSCH. HARZ, STEIN	350/20mm; 14"	ABRAS. BLADE, STONE	DISQUE SYNTH. BÉTON	DISCO SINT. PEDRA
8	350	1	1	1	1	1	1	1	1	1	1	1	1	1	1	1	1	1	1	1	1	1	1	1	1	1	1	966 161 050		TRENNSCH. HARZ, STAHL	400/20mm; 16"	ABRAS. BLADE, STEEL	DISQUE SYNTH. ACIER	DISCO SINT. ACERO
8	350	1	1	1	1	1	1	1	1	1	1	1	1	1	1	1	1	1	1	1	1	1	1	1	1	1	1	966 161 020		TRENNSCH. HARZ, STEIN	400/20mm; 16"	ABRAS. BLADE, STONE	DISQUE SYNTH. BÉTON	DISCO SINT. PEDRA
8	360	1	1	1	1	1	1	1	1	1	1	1	1	1	1	1	1	1	1	1	1	1	1	1	1	1	1	966 321 020	Acc.	DIAMANT, BETON DIADURAN	300/20mm; 12"	DIAMOND BLADE CONCR. DIADURAN	DISQUE DIAMANT, BÉTON DIADURAN	DISCO DIAMAN., HORMIGÓN DIADURAN
8	360	1	1	1	1	1	1	1	1	1	1	1	1	1	1	1	1	1	1	1	1	1	1	1	1	1	1	966 221 011	Acc.	DIAMANT, ASPHALT STANDARD	300/20mm; 12"	DIAMOND BLADE ASPHALT STAND.	DISQUE DIAMANT, ASPHALTE STAND.	DISCO DIAMAN., ASFALTO STAND.
8	360	1	1	1	1	1	1	1	1	1	1	1	1	1	1	1	1	1	1	1	1	1	1	1	1	1	1	966 221 029	Acc.	DIAMANT NEUTRON, BETON	300/20mm; 12"	DIAMOND NEUTRON, CONCRETE	DIAMANT NEUTRON, BÉTON	DIAMANT NEUTRON, HORMIGÓN
8	360	1	1	1	1	1	1	1	1	1	1	1	1	1	1	1	1	1	1	1	1	1	1	1	1	1	1	966 244 013	Acc.	DIAMANT, ASPHALT STANDARD	350/25,4mm; 14"	DIAMOND BLADE ASPHALT STAND.	DISQUE DIAMANT, ASPHALTE STAND.	DISCO DIAMAN., ASFALTO STAND.

DPC6430, DPC6431, DPC7330, DPC7331, DPC8131,
DPC8132, DPC6440, DPC6441, DPC7340, DPC7341,
DPC6430, DPC7331, DPC8131, DPC8132, DPC6440
, DPC7341, DPC6430, DPC6431, DPC7330, DPC7331
, DPC8131, DPC8132, DPC6440, DPC6441,
DPC7340, DPC7341

8

Trennscheiben, Werkzeug
Blades, tools
Disques, outils
Discos para dividir, herramientas

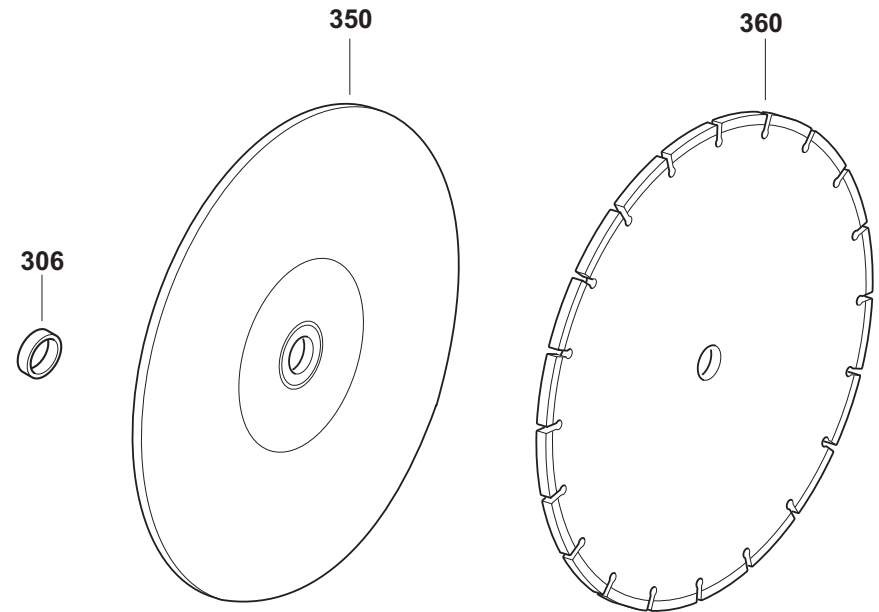
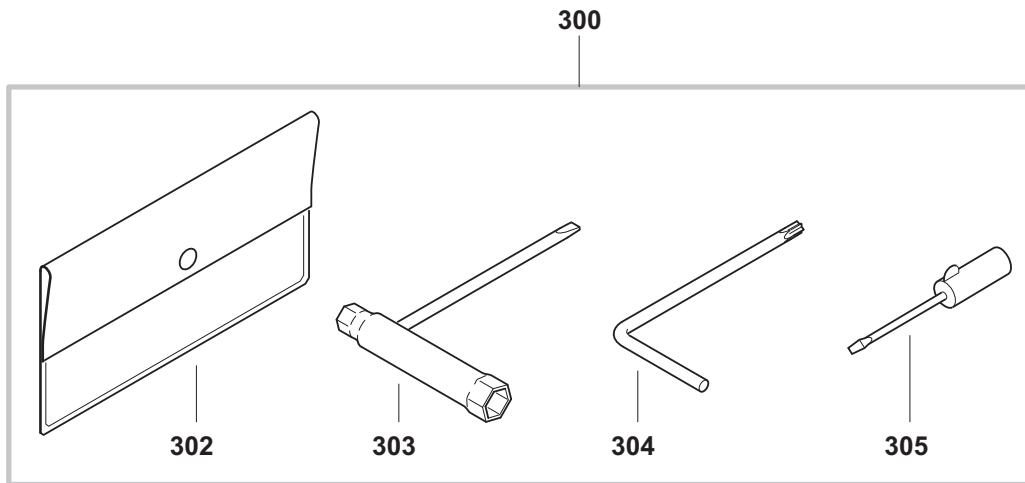

DPC6430, DPC6431, DPC7330, DPC7331, DPC8131,
DPC8132, DPC6440, DPC6441, DPC7340, DPC7341,
DPC6430, DPC7331, DPC8131, DPC8132, DPC6440
, DPC7341, DPC6430, DPC6431, DPC7330, DPC7331
, DPC8131, DPC8132, DPC6440, DPC6441,
DPC7340, DPC7341

8

Trennscheiben, Werkzeug
Blades, tools
Disques, outils
Discos para dividir, herramientas



Seite / Page	Pos.	DPC6430	DPC6431	DPC7330	DPC7331	DPC8131	DPC8132	DPC6440	DPC6441	DPC7340	DPC7341	DPC6430 (UK)	DPC7331 (UK)	DPC8131 (UK)	DPC8132 (UK)	DPC6440 (UK)	DPC7341 (UK)	DPC6430 (USA)	DPC6431 (USA)	DPC7330 (USA)	DPC7331 (USA)	DPC8131 (USA)	DPC8132 (USA)	DPC6440 (USA)	DPC6441 (USA)	DPC7340 (USA)	DPC7341 (USA)	Teil-Nr. Part No. No. de pièce No. de pieza	Hinweise Notes Renseign. Nota	Bezeichnung	Spezifikation Specification	Description	Désignation	Denominación
8	360	1		1	1			1		1			1	1			1		1		1	1			1		1	966 241 011	Acc.	DIAMANT, ASPHALT STANDARD	350/20mm; 14"	DIAMOND BLADE ASPHALT STAND.	DISQUE DIAMANT, ASPHALTE STAND.	DISCO DIAMAN., ASFALTO STAND.
8	360	1		1	1			1		1			1	1			1		1		1	1			1		1	966 341 010	Acc.	DIAMANT, ASPHALT DIADURAN	350/20mm; 14"	DIAMOND BLADE ASPH. DIADURAN	DISQUE DIAMANT, ASPH. DIADURAN	DISCO DIAMAN., ASFALTO DIADURAN
8	360	1		1	1			1		1			1	1			1		1		1	1			1		1	966 344 010	Acc.	DIAMANT, ASPHALT DIADURAN	350/25,4mm; 14"	DIAMOND BLADE ASPH. DIADURAN	DISQUE DIAMANT, ASPH. DIADURAN	DISCO DIAMAN., ASFALTO DIADURAN
8	360	1		1	1			1		1			1	1			1		1		1	1			1		1	966 244 030	Acc.	DIAMANT, BETON STANDARD	350/25,4mm; 14"	DIAMOND BLADE CONCR. STAND.	DISQUE DIAMANT, BÉTON STAND.	DISCO DIAMAN., HORMIGÓN STAND.
8	360	1		1	1			1		1			1	1			1		1		1	1			1		1	966 241 022	Acc.	DIAMANT, BETON STANDARD	350/20mm; 14"	DIAMOND BLADE CONCR. STAND.	DISQUE DIAMANT, BÉTON STAND.	DISCO DIAMAN., HORMIGÓN STAND.
8	360	1		1	1			1		1			1	1			1		1		1	1			1		1	966 344 020	Acc.	DIAMANT, BETON DIADURAN	350/25,4mm; 14"	DIAMOND BLADE CONCR. DIADURAN	DISQUE DIAMANT, BÉTON DIADURAN	DISCO DIAMAN., HORMIGÓN DIADURAN
8	360	1		1	1			1		1			1	1			1		1		1	1			1		1	966 341 020	Acc.	DIAMANT, BETON DIADURAN	350/20mm; 14"	DIAMOND BLADE CONCR. DIADURAN	DISQUE DIAMANT, BÉTON DIADURAN	DISCO DIAMAN., HORMIGÓN DIADURAN
8	360			1	1					1											1	1					1	966 544 060		DIAMANT, UNIV. RESCUE FORCE	350/25,4mm; 14"	DIAMANT, UNIV. RESCUE FORCE	DIAMANT, UNIV. RESCUE FORCE	DIAMANT, UNIV. RESCUE FORCE

DPC6430, DPC6431, DPC7330, DPC7331, DPC8131,
DPC8132, DPC6440, DPC6441, DPC7340, DPC7341,
DPC6430, DPC7331, DPC8131, DPC8132, DPC6440
, DPC7341, DPC6430, DPC6431, DPC7330, DPC7331
, DPC8131, DPC8132, DPC6440, DPC6441,
DPC7340, DPC7341

9

Wasseranschluß, Druckwassertank • Nicht im Lieferumfang
Water attachment, pressurised water tank • Not included in delivery
Raccordement d'eau, réservoir d'eau sous pres. • Non incl. dans la livraison
Acometida de agua, tanque de agua a pres. • No incluidos en entrega

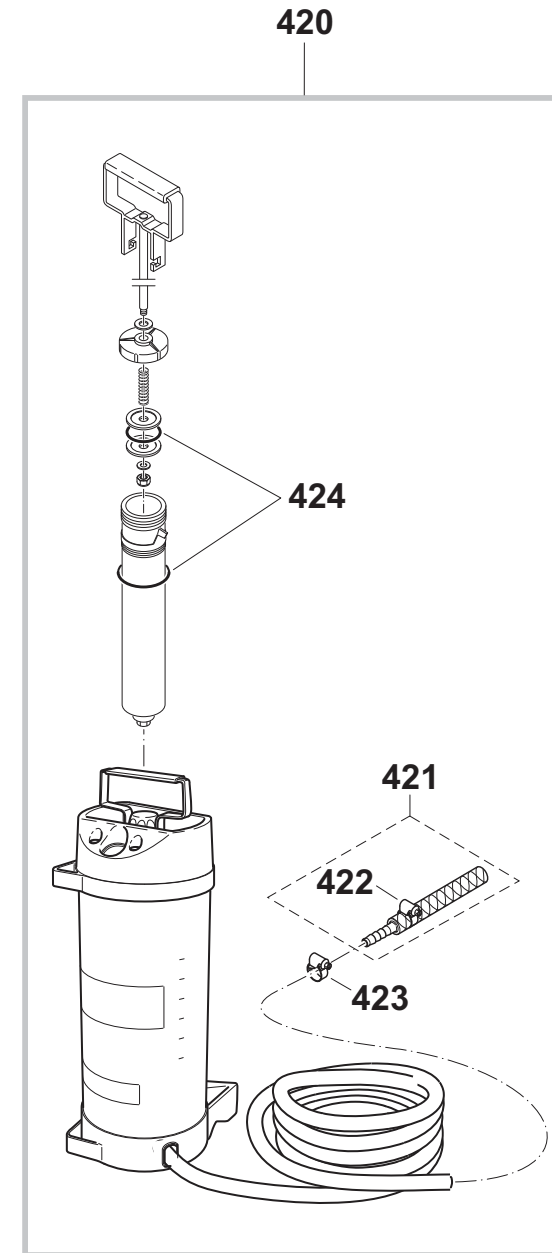
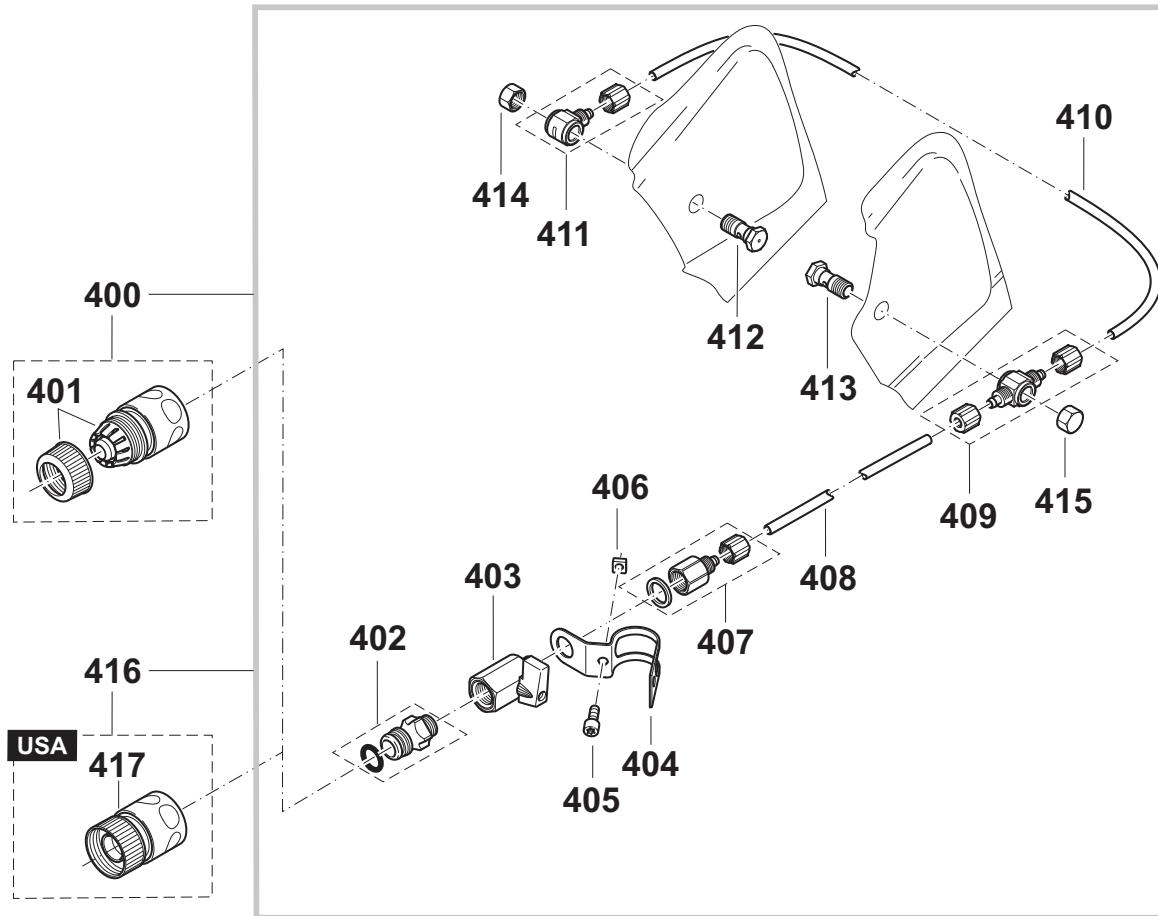

DPC6430, DPC6431, DPC7330, DPC7331, DPC8131, DPC8132, DPC6440, DPC6441, DPC7340, DPC7341, DPC6430, DPC7331, DPC8131, DPC8132, DPC6440, DPC7341, DPC6430, DPC6431, DPC7330, DPC7331, DPC8131, DPC8132, DPC6440, DPC6441, DPC7340, DPC7341

9

Wasseranschluß, Druckwassertank • Nicht im Lieferumfang
Water attachment, pressurised water tank • Not included in delivery
Raccordement d'eau, réservoir d'eau sous pres. • Non incl. dans la livraison
Acometida de agua, tanque de agua a pres. • No incluidos en entrega



Seite / Page	Pos.	DPC6430	DPC6431	DPC7330	DPC7331	DPC8131	DPC8132	DPC6440	DPC6441	DPC7340	DPC7341	DPC6430 (UK)	DPC7331 (UK)	DPC8131 (UK)	DPC8132 (UK)	DPC6440 (UK)	DPC7341 (UK)	DPC6430 (USA)	DPC6431 (USA)	DPC7330 (USA)	DPC7331 (USA)	DPC8131 (USA)	DPC8132 (USA)	DPC6440 (USA)	DPC6441 (USA)	DPC7340 (USA)	DPC7341 (USA)	Teil-Nr. Part No. No. de pièce No. de pieza	Hinweise Notes Renseign. Nota	Bezeichnung	Spezifikation Specification	Description	Désignation	Denominación	
9	400	1	1	1	1	1	1	1	1	1	1	1	1	1	1	1	1											394 365 102		DRUCK-, FALLWASSERARM ATUR		WATER ATTACHMENT KIT	JEU DE RACCORDEMENT D'EAU	ACOMETIDA DE AGUA	
9	401	1	1	1	1	1	1	1	1	1	1	1	1	1	1	1	1											964 802 271		SCHLAUCHKUPPL UNG	STOP	COUPLING SLEEVE	MANCHON D'ACCOUPLEMEN T	ACOPLAMIENT O P. TUBOS	
9	402	1	1	1	1	1	1	1	1	1	1	1	1	1	1	1	1	1	1	1	1	1	1	1	1	1	1	964 802 282		EINSCHRAUBNIPP EL		HOSE CONNECTOR	RACCORD POUR TUYAU	BOQUILLA ROSCADA	
9	403	1	1	1	1	1	1	1	1	1	1	1	1	1	1	1	1	1	1	1	1	1	1	1	1	1	1	964 802 291		KUGELVENTIL		SHUT OFF COCK	ROBINET D'ARRÊT	LLAVE DE PASO	
9	404	1	1	1	1	1	1	1	1	1	1	1	1	1	1	1	1	1	1	1	1	1	1	1	1	1	1	394 365 163		SCHELLE		CLAMP	BRIDE DE FIXATION	ABRAZADERA	
9	405	1	1	1	1	1	1	1	1	1	1	1	1	1	1	1	1	1	1	1	1	1	1	1	1	1	1	909 006 145		SCHRAUBE	M6x14	SCREW	VIS	TORNILLO	
9	406	1	1	1	1	1	1	1	1	1	1	1	1	1	1	1	1	1	1	1	1	1	1	1	1	1	1	921 906 004		4KT-MUTTER	M6	SQUARE NUT	ECROU CARRÉ	TUERCA CUADR.	
9	407	1	1	1	1	1	1	1	1	1	1	1	1	1	1	1	1	1	1	1	1	1	1	1	1	1	1	964 802 410		SCHNELLVERSCH RAUBUNG		CONNECTING PIECE	PIÈCE DE RACCORD	PIEZA DE UNIÓN	
9	408	m	m	m	m	m	m	m	m	m	m	m	m	m	m	m	m	m	m	m	m	m	m	m	m	m	m	m	964 802 322		PU-SCHLAUCH	405mm; 16"	HOSE	TUYAU	TUBO
9	409	1	1	1	1	1	1	1	1	1	1	1	1	1	1	1	1	1	1	1	1	1	1	1	1	1	1	964 802 332		SCHNELLVERSCH RAUBUNG	T	CONNECTING PIECE	PIÈCE DE RACCORD	PIEZA DE UNIÓN	
9	410	m	m	m	m	m	m	m	m	m	m	m	m	m	m	m	m	m	m	m	m	m	m	m	m	m	m	964 802 322		PU-SCHLAUCH	180mm; 7"	HOSE	TUYAU	TUBO	
9	410	m	m	m	m	m	m	m	m	m	m	m	m	m	m	m	m	m	m	m	m	m	m	m	m	m	m	964 802 322		PU-SCHLAUCH	210mm; 8 1/4"	HOSE	TUYAU	TUBO	
9	411	1	1	1	1	1	1	1	1	1	1	1	1	1	1	1	1	1	1	1	1	1	1	1	1	1	1	964 802 340		SCHNELLVERSCH RAUBUNG	L	CONNECTING PIECE	PIÈCE DE RACCORD	PIEZA DE UNIÓN	
9	412	1	1	1	1	1	1	1	1	1	1	1	1	1	1	1	1	1	1	1	1	1	1	1	1	1	1	964 802 352		HOHLSCHRAUBE GEOHRT		HOLLOW SCREW, BORED	VIS	TORNILLO	
9	413	1	1	1	1	1	1	1	1	1	1	1	1	1	1	1	1	1	1	1	1	1	1	1	1	1	1	964 802 352		HOHLSCHRAUBE GEOHRT		HOLLOW SCREW, BORED	VIS	TORNILLO	
9	414	1	1	1	1	1	1	1	1	1	1	1	1	1	1	1	1	1	1	1	1	1	1	1	1	1	1	964 802 362		HUTMUTTER		CAP NUT	ÉCROU BORGNE	TUERCA	
9	415	1	1	1	1	1	1	1	1	1	1	1	1	1	1	1	1	1	1	1	1	1	1	1	1	1	1	964 802 362		HUTMUTTER		CAP NUT	ÉCROU BORGNE	TUERCA	
9	416																	1	1	1	1	1	1	1	1	1	1	394 365 630	U.S.A.	DRUCK-, FALLWASSERARM ATUR		WATER ATTACHMENT KIT	JEU DE RACCORDEMENT D'EAU	ACOMETIDA DE AGUA	
9	417																	1	1	1	1	1	1	1	1	1	1	964 802 400	U.S.A.	SCHLAUCHKUPPL UNG	STOP 1 1/16"	COUPLING SLEEVE	MANCHON D'ACCOUPLEMEN T	ACOPLAMIENT O P. TUBOS	
9	420	1	1	1	1	1	1	1	1	1	1	1	1	1	1	1	1	1	1	1	1	1	1	1	1	1	1	957 802 600		DRUCKWASSERTA NK	10 l	PRESSURISED WATER TANK	RÉSERVOIR D'EAU SOUS PRES.	TANQUE DE AGUA A PRES.	
9	421	1	1	1	1	1	1	1	1	1	1	1	1	1	1	1	1	1	1	1	1	1	1	1	1	1	1	394 365 180		SCHLAUCHADAPT ER		CONNECTING REDUCER	RACCORD RÉDUCTEUR	REDUCTOR	

DPC6430, DPC6431, DPC7330, DPC7331, DPC8131,
DPC8132, DPC6440, DPC6441, DPC7340, DPC7341,
DPC6430, DPC7331, DPC8131, DPC8132, DPC6440
, DPC7341, DPC6430, DPC6431, DPC7330, DPC7331
, DPC8131, DPC8132, DPC6440, DPC6441,
DPC7340, DPC7341

9

Wasseranschluß, Druckwassertank • Nicht im Lieferumfang
Water attachment, pressurised water tank • Not included in delivery
Raccordement d'eau, réservoir d'eau sous pres. • Non incl. dans la livraison
Acometida de agua, tanque de agua a pres. • No incluidos en entrega

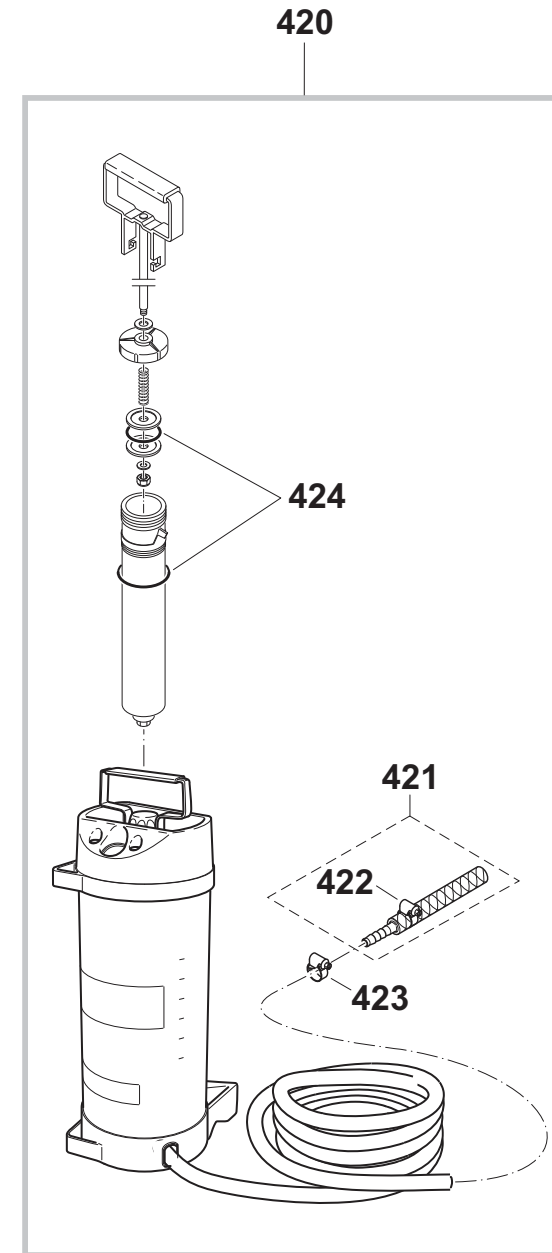
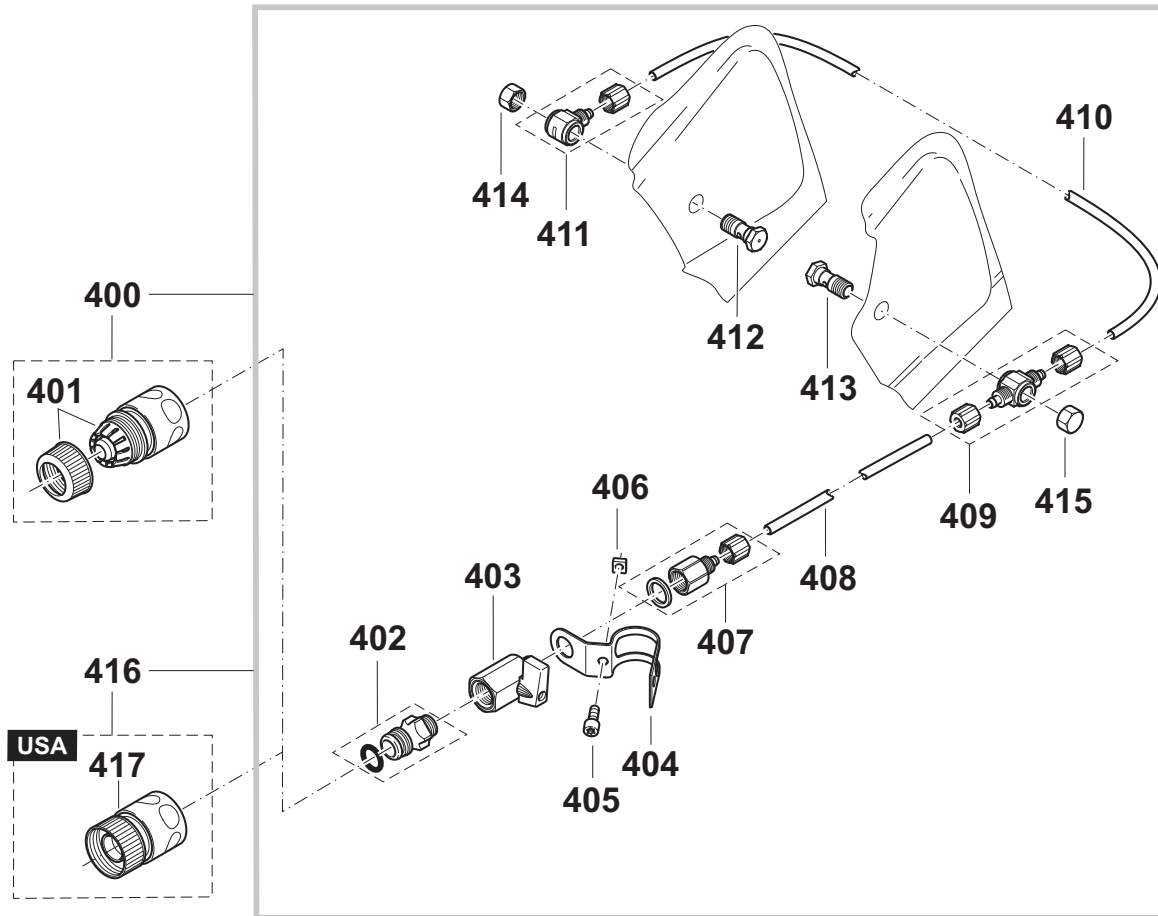

DPC6430, DPC6431, DPC7330, DPC7331, DPC8131,
 DPC8132, DPC6440, DPC6441, DPC7340, DPC7341,
 DPC6430, DPC7331, DPC8131, DPC8132, DPC6440
 , DPC7341, DPC6430, DPC6431, DPC7330, DPC7331
 , DPC8131, DPC8132, DPC6440, DPC6441,
 DPC7340, DPC7341

9

Wasseranschluß, Druckwassertank • Nicht im Lieferumfang
 Water attachment, pressurised water tank • Not included in delivery
 Raccordement d'eau, réservoir d'eau sous pres. • Non incl. dans la livraison
 Acometida de agua, tanque de agua a pres. • No incluidos en entrega



Seite / Page	Pos.	DPC6430	DPC6431	DPC7330	DPC7331	DPC8131	DPC8132	DPC6440	DPC6441	DPC7340	DPC7341	DPC6430 (UK)	DPC7331 (UK)	DPC8131 (UK)	DPC8132 (UK)	DPC6440 (UK)	DPC7341 (UK)	DPC6430 (USA)	DPC6431 (USA)	DPC7330 (USA)	DPC7331 (USA)	DPC8131 (USA)	DPC8132 (USA)	DPC6440 (USA)	DPC6441 (USA)	DPC7340 (USA)	DPC7341 (USA)	Teil-Nr. Part No. No. de pièce No. de pieza	Hinweise Notes Renseign. Nota	Bezeichnung	Spezifikation Specification	Description	Désignation	Denominación
9	422	1	1	1	1	1	1	1	1	1	1	1	1	1	1	1	1	1	1	1	1	1	1	1	1	1	1	964 802 250		SCHLAUCHSCHEL LE	ø10-16 mm	HOSE CLIP	COLLIER DE SERRAGE	ABRAZADERA
9	423	1	1	1	1	1	1	1	1	1	1	1	1	1	1	1	1	1	1	1	1	1	1	1	1	1	964 802 250		SCHLAUCHSCHEL LE	ø10-16 mm	HOSE CLIP	COLLIER DE SERRAGE	ABRAZADERA	
9	424	1	1	1	1	1	1	1	1	1	1	1	1	1	1	1	1	1	1	1	1	1	1	1	1	1	957 963 200		DICHTUNGSSATZ		GASKET SET	JEU DE JOINTS	JUEGO JUNTAS	

DPC6430, DPC6431, DPC7330, DPC7331, DPC8131,
 DPC8132, DPC6440, DPC6441, DPC7340, DPC7341,
 DPC6430, DPC7331, DPC8131, DPC8132, DPC6440
 , DPC7341, DPC6430, DPC6431, DPC7330, DPC7331
 , DPC8131, DPC8132, DPC6440, DPC6441,
 DPC7340, DPC7341



	Zeichenerklärung	Key to symbols	Légende	Explicación de símbolos
=> 1999999 2000000 => 2003.04 => TI 2003/07 Acc. = { m Corr.	Produktion bis Serien-Nr. Neues Teil ab Serien-Nr. Neues Teil ab Jahr / Monat Siehe Technische Information Jahr / Nr. Zubehör (nicht im Lieferumfang) Keine Serienausführung, jedoch verwendbar Beinhaltet Positions-Nr. Meterware Druckfehlerberichtigung	Production to serial number New part from serial number New part from Year / Month See Technical Information Year / No. Accessories (not included in the delivery inventory) No standard execution, may be used Contains item number Sold by the meter Error correction	Production jusqu'à n° de série Nouveau pièce à partir du n° de série Nouveau pièce à partir de année / mois Voir information technique année / n° Accessoires (non compris dans la livraison) Aucune exécut. en série, cependant utilisable contient n° de numéro Au mètre Rectification d'erreurs	Producción hasta N° de serie Pieza nueva a partir de N° de serie Pieza nueva a partir de año / mes Véase inform. técnico año / N° Accesorios (no incluido en la extensión del suministro) No es de serie, pero sirve Contiene pos N° Por metro Fe de erratas
	Änderungen vorbehalten	Specifications subject to change without notice	Changements sans préavis	Mejoras constructivas sin previo aviso