

6" BENCH GRINDER PARTS DIAGRAM
(WITH KNIFE GRINDING REST)

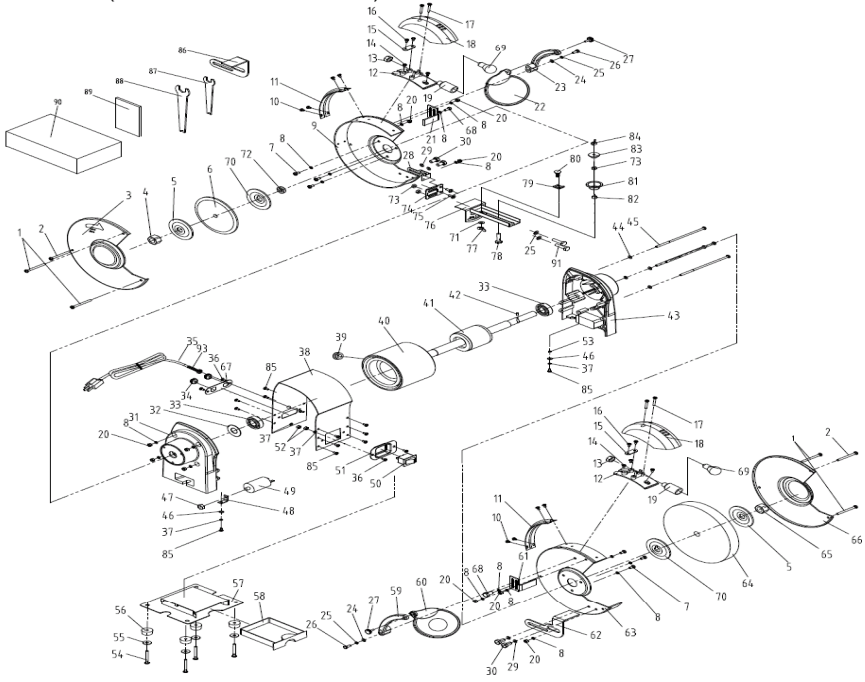

Pos.	Item No.	Description	Qty
1	AL00000143	Phillip screw	4
2	AL00000106	Phillip screw	2
3	AL00000002	Left wheel cover	1
4	AL00000003	I type hex nut	1
5	AL00000004	Grinder outer clamp	2
7	AL00000110	Phillip screw	6
6	A-47210	Grinding wheel (WA 60#)	1
8	AL00000132	Standard spring washer	18
9	AL00000006	Left wheel guard (inner)	1
10	AL00000114	Little phillip screw	8
11	AL00000007	Cord press plate	2
12	AL00000008	Lamp base cover	2
13	AL00000009	Lamp holder retaining nut	2
14	AL00000102	Phillip screw	4
15	AL00000010	Strain relief	2
16	AL00000104	Phillip screw	4
17	AL00000105	Phillip screw	4
18	AL00000011	Lamp cover assy	2
19	AL00000012	Lamp assy	2
20	AL00000121	I type hex nut	10
21	AL00000017	Left spark shield	1
22	AL00000016	Eyeshield assy	1
23	AL00000015	Left eyeshield mount rod	1
24	AL00000127	Plain washer	2
25	AL00000133	Standard spring washer	2
26	AL00000116	Hex bolt	2
27	AL00000014	Hex shield lock knot	2
28	AL00000018	Left work rest	1
29	AL00000128	Flat washer	4
30	AL00000118	Hex bolt	4
31	AL00000028	Left end cap	1
32	AL00000027	wave spring washer	1
33	AL00000100	Ball bearing	2
34	AL00000026	Cord clip	2
35	AL00000152	Wire with plug	1
36	AL00000103	Phillip screw	4
37	AL00000131	Standard spring washer	6
38	AL00000023	Motor housing	1
39	AL00000022	Wire bushing	1
40	AL00000185	Stator	1
41	AL00000020	Rotor	1
42	AL00000135	Roll pin	2
43	AL00000019	Right end cap	1
44	AL00000126	Plain washer	4
45	AL00000113	Phillip screw	4
46	AL00000146	Plain washer	2
47	AL00000122	I type hex nut	1
48	AL00000029	Capacitor support	1
49	AL00000095	Capacitor	1
50	AL00000141	Switch	1

6" BENCH GRINDER PARTS DIAGRAM
(WITH KNIFE GRINDING REST)

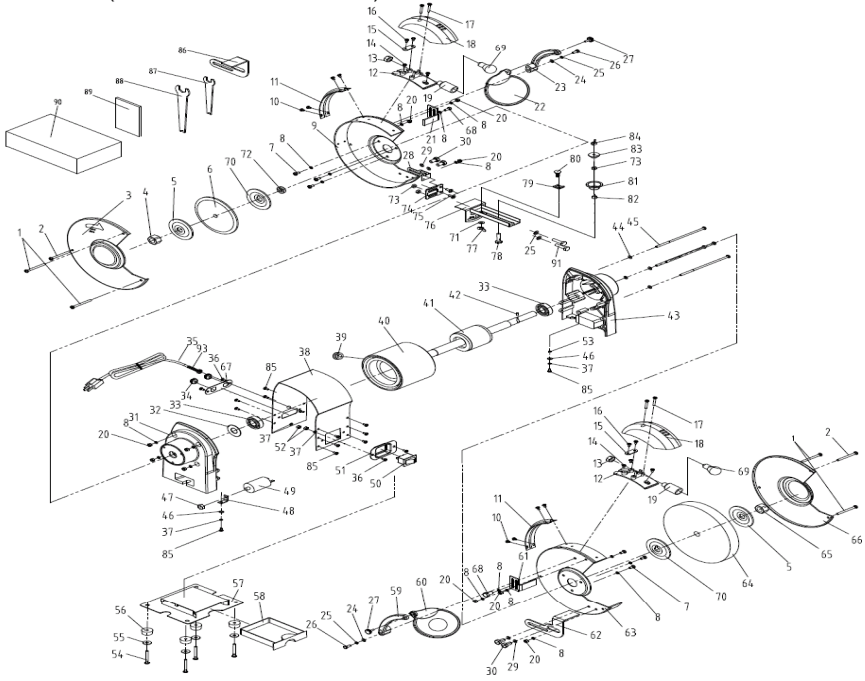

Pos.	Item No.	Description	Qty
51	AL00000031	Switch board	1
52	AL00000120	I type hex nut	4
53	AL00000134	tooth locked washer	1
54	AL00000109	Philip screw	4
55	AL00000129	Big flat washer	4
56	AL00000041	Rubber foot	4
57	AL00000040	Coolant tray plate assy	1
58	AL00000039	Coolant tray	1
59	AL00000038	Right eyeshield mount rod	1
60	AL00000037	Magnifying glass assy	1
61	AL00000036	Right spark shield	1
62	AL00000043	Right work rest	1
63	AL00000042	Right wheel guard(inner)	1
64	A-47204	Grinding wheel (GC 120#)	1
65	AL00000035	I type hex nut	1
66	AL00000034	Right wheel cover	1
67	AL00000024	Cord Clip Plate	1
68	AL00000115	Hex bolt	2
69	AL00000013	Bulb	2
70	AL00000005	Grinder inner clamp	2
71	AL00000108	Philip screw	12
72	AL00000045	Hex wrench I	1
73	AL00000044	Hex wrench II	1
74	AL00000162	MANUAL-ENGLISH CE	1
75	AL00000153	Package	1
76	AL00000167	MANUAL-ERO 8	1
77	AL00000147	Eyeshield	1
77	AL00000010	Strain relief	1