

Ersatzteilliste
Spare Parts List
Liste de pièces détachées
Lista de piezas de repuesto

2003-11

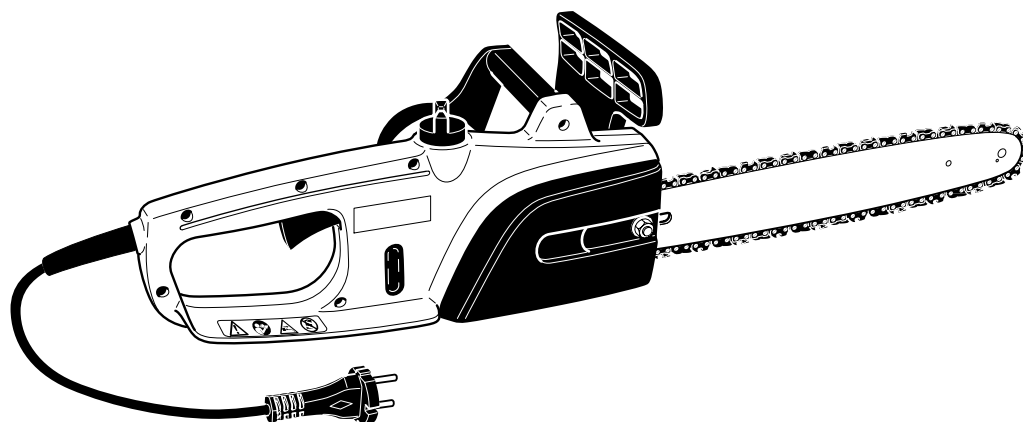

ES-4 A

ES-5 A

ES-6 A

ES-31 A

ES-36 A

ES-40 A

ES-32 A

ES-37 A

ES-41 A

DOLMAR



995 700 233 (D, GB, F, E)

ES-4 A, 5 A, 6 A
ES-31 A, 32 A
ES-36 A, 37 A
ES-40 A, 41 A

1

Gehäuse links, Handschutz, Motor
Case left, hand guard, motor
Carter gauche, protège-main, moteur
Cárter izqu., protector de mano, motor

DOLMAR

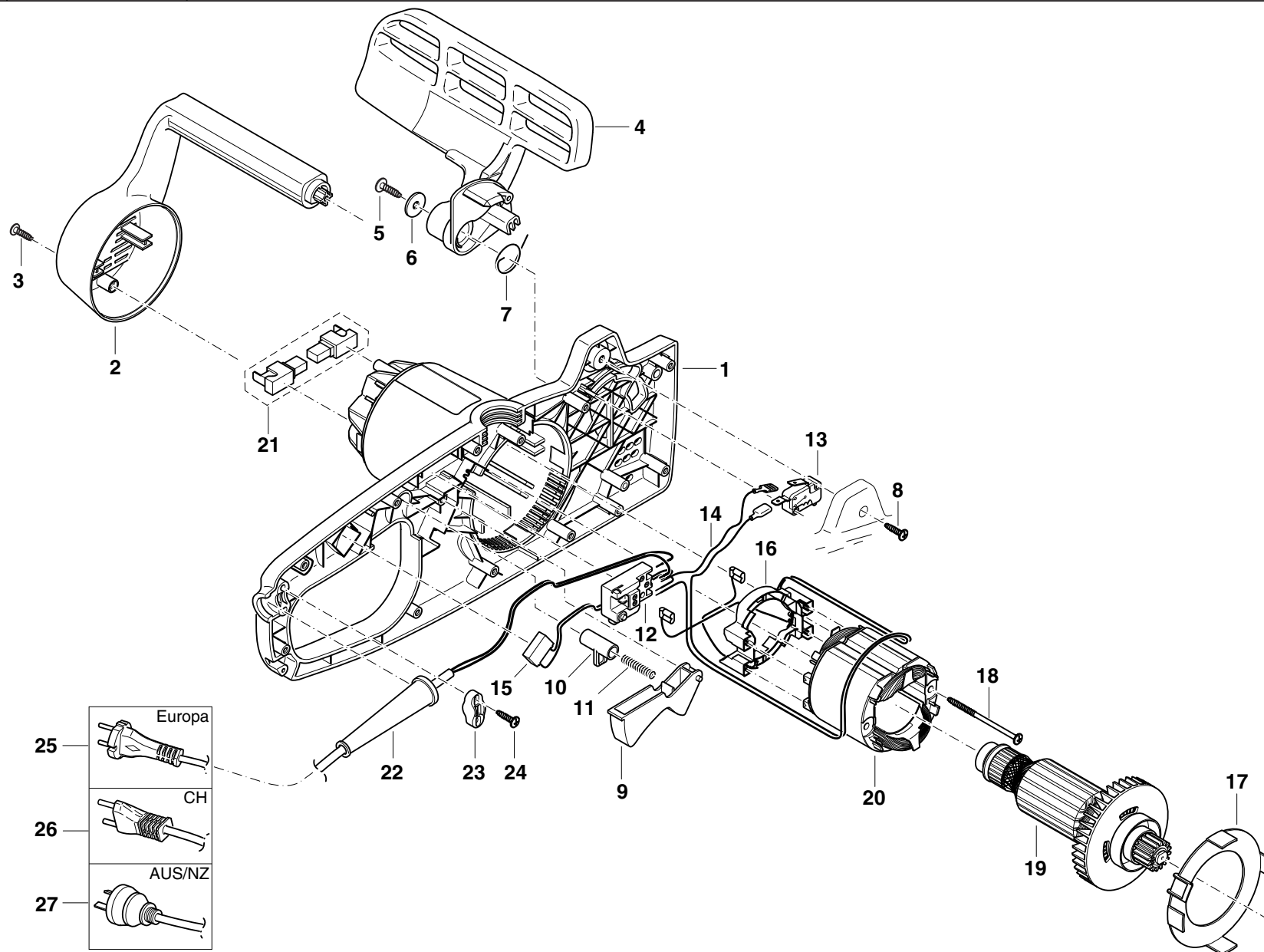

**ES-4A, 5A, 6A, 31A, 32A, 36A,
37A, 40A, 41A**



Seite / Page	Pos.	ES-4 A	ES-5 A	ES-6 A	ES-31 A	ES-36 A	ES-40 A	ES-32 A	ES-37 A	ES-41 A	Teil-Nr. Part No. No. de pièce No. de pieza	Hinweise Notes Renseign. Nota	Bezeichnung	Spezifikation Specification	Description	Désignation	Denominación
1	1	1	1	1	1	1	1	1	1	1	210 111 010		Gehäuse links, rot		Case left cpl., red	Carter gauche cpl., rouge	Cárter izqu. cpl., rojo
1	2	1	1	1	1	1	1	1	1	1	210 310 010		Vorderer Handgriff		Front handle	Poignée d' avance	Mango delantero
1	3	2	2	2	2	2	2	2	2	2	913 540 185		Schraube	4x18	Screw	Vis	Tornillo
1	4	1	1	1	1	1	1	1	1	1	210 213 040		Handschutz		Hand guard	Protège-main	Protector de mano
1	5	1	1	1	1	1	1	1	1	1	913 550 165		Schraube	5x16	Screw	Vis	Tornillo
1	6	1	1	1	1	1	1	1	1	1	924 605 510		Scheibe	ø5,5/18x1,6	Washer	Rondelle	Arandela
1	7	1	1	1	1	1	1	1	1	1	210 213 030		Feder für Handschutz		Spring for hand guard	Ressort pour protège-main	Muelle p. prot. de mano
1	8	1	1	1	1	1	1	1	1	1	913 540 185		Schraube	4x18	Screw	Vis	Tornillo
1	9	1	1	1	1	1	1	1	1	1	210 144 010		Schalthebel		Switch button	Poignée de commande	Palanca de interruptor
1	10	1	1	1	1	1	1	1	1	1	225 144 010		Sperrknopf		Locking button	Bouton de blocage	Botón de bloqueo
1	11	1	1	1	1	1	1	1	1	1	225 145 010		Druckfeder für Sperrknopf		Pressure spring	Ressort de pression	Resorte de presión
1	12	1	1	1	1	1	1	1	1	1	975 001 200		Druckknopfschalter		Push button	Bouton-poussoir	Interruptor pulsador
1	13	1	1	1	1	1	1	1	1	1	970 001 200		Mikroschalter (Schließer)		Switch	Interrupteur	Interruptor
1	14	1	1	1	1	1	1	1	1	1	970 311 500		Verbindungskabel	L=170mm	Connecting cable	Câble de raccordem.	Cable de conexión
1	15	1	1	1	1	1	1	1	1	1	970 109 820		Kondensator		Capacitor	Condensateur	Condensador
1	16	1	1	1	1	1	1	1	1	1	970 803 280		Anschlußplatte kpl.		Connecting board cpl.	Platine de raccordement cpl.	Placa de conexiones cpl.
1	17	1	1	1	1	1	1	1	1	1	210 118 010		Lufführung		Air guide plate	Guide d' air	Conducto de aire
1	18	2	2	2	2	2	2	2	2	2	913 550 655		Schraube	5x65	Screw	Vis	Tornillo
1	19	1	1	1	1	1	1	1	1	1	970 803 390		Rotor kpl.	220-240V	Rotor assy.	Rotor cpl.	Rotor cpl.
1	20	1	1	1	1	1	1	1	1	1	970 803 230		Stator kpl.	220-240V	Stator assy.	Stator cpl.	Estator cpl.
1	21	2	2	2	2	2	2	2	2	2	957 823 410		Kohlebürste (2 Stck.)		Carbon brush (2 pcs.)	Jeu de balais (2 piè.)	Escob. de carb. (2 pzs.)
1	22	1	1	1	1	1	1	1	1	1	225 152 010		Knickschutz		Break protection	Passe-câble	Boquilla de paso
1	23	1	1	1	1	1	1	1	1	1	225 152 060		Zugentlastung, rot		Traction relief, red	Collier, rouge	Dispos. contratr., rojo
1	24	2	2	2	2	2	2	2	2	2	913 540 185		Schraube	4x18	Screw	Vis	Tornillo
1	25	1	1	1	1	1	1	1	1	1	970 102 310		Kabel mit Stecker	EUROPA	Cable with plug	Câble avec prise	Cable con enchufe
1	26	1	1	1	1	1	1	1	1	1	970 102 350		Kabel mit Stecker	CH	Cable with plug	Câble avec prise	Cable con enchufe
1	27				1	1	1				970 102 360		Kabel mit Stecker	AUS, NZ	Cable with plug	Câble avec prise	Cable con enchufe

ES-4 A, 5 A, 6 A
ES-31 A, 32 A
ES-36 A, 37 A
ES-40 A, 41 A

2

Gehäuse rechts, Getriebe, Kettenbremse
Case right, gear, chain brake
Carter droit, engrenage, frein de chaîne
Cárter der., engranaje, freno de cadena

DOLMAR

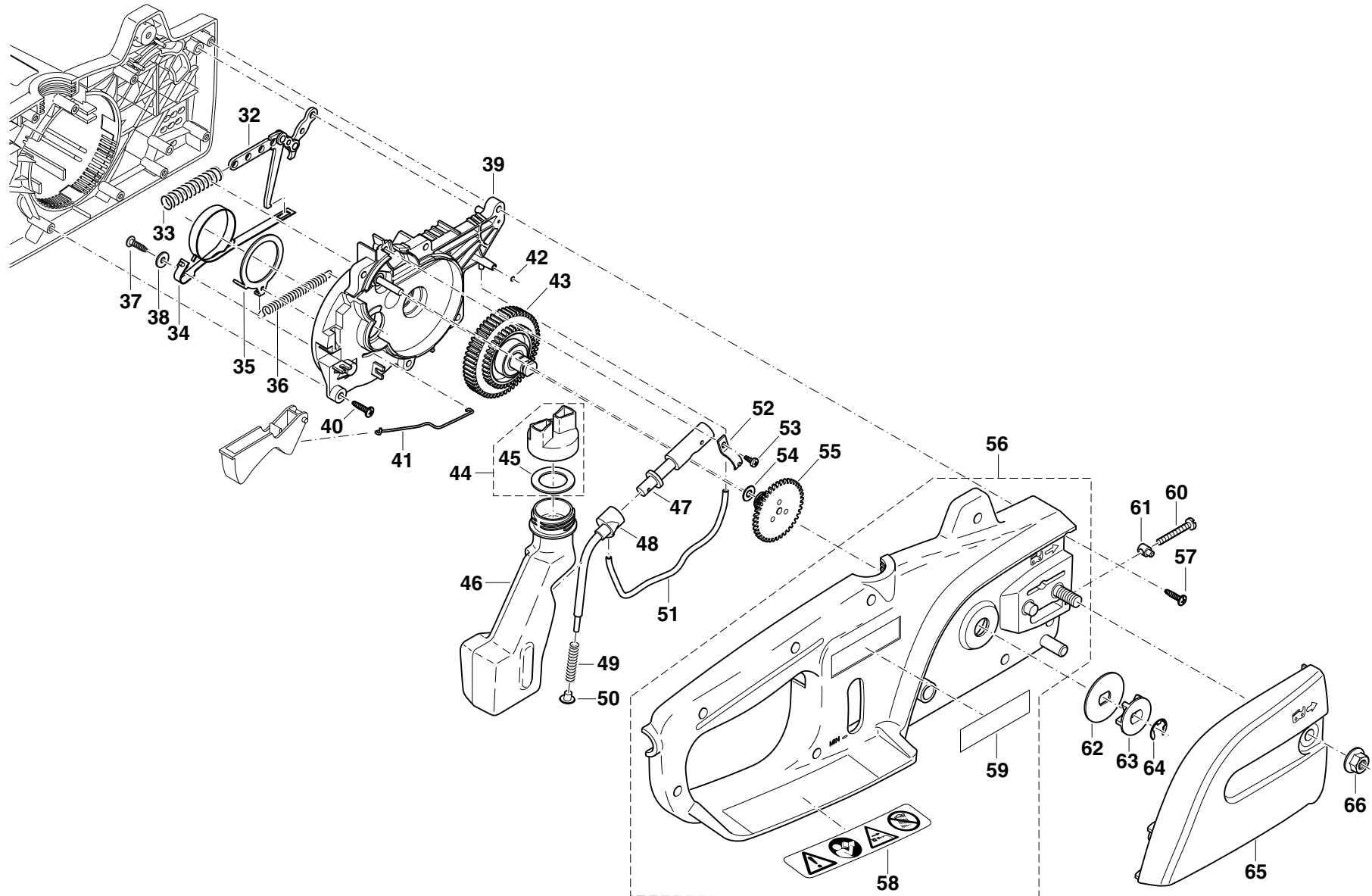

**ES-4A, 5A, 6A, 31A, 32A, 36A,
37A, 40A, 41A**



Seite / Page	Pos.	ES-4 A	ES-5 A	ES-6 A	ES-31 A	ES-36 A	ES-40 A	ES-32 A	ES-37 A	ES-41 A	Teil-Nr. Part No. No. de pièce No. de pieza	Hinweise Notes Renseign. Nota	Bezeichnung	Spezifikation Specification	Description	Désignation	Denominación
2	32	1	1	1	1	1	1	1	1	1	210 213 301		Bremsbandhalter kpl.		Brake spring holder cpl.	Support d. ressort d. frein cpl.	Soporte d. cinta d. freno cpl.
2	33	1	1	1	1	1	1	1	1	1	028 213 521		Speicherfeder für Bremse		Spring	Ressort	Resorte
2	34	1	1	1	1	1	1	1	1	1	210 213 500		Bremsband		Brake spring	Ressort de frein	Cinta de freno
2	35	1	1	1	1	1	1	1	1	1	210 213 020		Bremsring		Brake ring	Bague de freinage	Anillo de freno
2	36	1	1	1	1	1	1	1	1	1	210 213 051		Zugfeder		Spring	Ressort	Resorte
2	37	1	1	1	1	1	1	1	1	1	913 540 185		Schraube	4x18	Screw	Vis	Tornillo
2	38	1	1	1	1	1	1	1	1	1	924 204 320		Scheibe	ø4,3/12x1,2	Washer	Rondelle	Arandela
2	39	1	1	1	1	1	1	1	1	1	210 211 100		Getriebeplatte kpl.		Gear plate cpl.	Porte-engrenage cpl.	Porta engranaje cpl.
2	40	5	5	5	5	5	5	5	5	5	913 540 185		Schraube	4x18	Screw	Vis	Tornillo
2	41	1	1	1	1	1	1	1	1	1	210 271 080		Schaltstange		Switch rod	Tringle de commande	Vara conmutadora
2	42	1	1	1	1	1	1	1	1	1	963 203 010		O-Ring	ø3,5x1	O-ring	Joint torique	Anillo de guarnición
2	43	1	1	1	1	1	1	1	1	1	210 221 100		Getrieberad kpl.		Gear cpl.	Engrenage cpl.	Engranaje cpl.
2	44	1	1	1	1	1	1	1	1	1	205 114 202		Tankverschluß kpl.		Tank plug cpl.	Bouchon réservoir cpl.	Cierre depósito cpl.
2	45	1	1	1	1	1	1	1	1	1	963 100 081		Dichtung		Gasket	Joint	Junta
2	46	1	1	1	1	1	1	1	1	1	210 114 020		Öltank		Oil tank	Réservoir d' huile	Depósito de aceite
2	47	1	1	1	1	1	1	1	1	1	021 245 003		Ölpumpe kpl.		Oil pump cpl.	Pompe à huile cpl.	Bomba de aceite cpl.
2	48	1	1	1	1	1	1	1	1	1	965 451 210		Ölpumpenanschluß		Connection for oil pump	Connexion p. pompe à huile	Conexión p. bomba de acei.
2	49	1	1	1	1	1	1	1	1	1	021 245 060		Druckfeder		Pressure spring	Ressort de pression	Resorte de presión
2	50	1	1	1	1	1	1	1	1	1	021 245 100		Stopfen		Plug	Bouchon	Tapón
2	51	1	1	1	1	1	1	1	1	1	965 452 388		Schlauch	L=230mm	Tube	Gaine	Tubo
2	51	m	m	m	m	m	m	m	m	m	965 452 380		Schlauch		Tube	Gaine	Tubo
2	52	1	1	1	1	1	1	1	1	1	203 245 001		Halter für Ölpumpe		Holder for oil pump	Crampon p. pompe à huile	Empuñadura p. bomba
2	53	1	1	1	1	1	1	1	1	1	915 735 100		Schraube	3,5x10	Screw	Vis	Tornillo
2	54	1	1	1	1	1	1	1	1	1	925 305 000		Scheibe	ø5/12x0,5	Washer	Rondelle	Arandela
2	55	1	1	1	1	1	1	1	1	1	210 221 030		Antriebsrad Ölpumpe		Drive wheel, oil pump	Roue d'entraînement	Rueda de impulsión
2	56	1	1	1	1	1	1	1	1	1	210 110 020		Gehäuse rechts kpl., rot		Case right cpl., red	Carter droit cpl., rouge	Cárter der. cpl., rojo
2	57	8	8	8	8	8	8	8	8	8	913 540 185		Schraube	4x18	Screw	Vis	Tornillo
2	58	1	1	1	1	1	1	1	1	1	980 114 181		Sicherheitsaufkleber		Label	Plaque	Calcomania
2	59	1	1	1	1	1	1	1	1	1	980 114 347		Schild	DOLMAR	Label	Plaque	Calcomania
2	60				1	1	1				901 505 354		Schraube	M5x35	Screw	Vis	Tornillo
2	61				1	1	1				001 213 042		Mutter mit Zapfen		Nut with pivot	Ecrou avec pivot	Tuerca con espiga
2	62	1	1	1	1	1	1	1	1	1	210 224 050		Anlaufscheibe	ø40x1	Stop disc	Disque portante	Disco de tope
2	63	1	1	1	1	1	1	1	1	1	210 224 010		Kettenritzel	3/8"	Rim sprocket	Pignon	Piñón
2	64	1	1	1	1	1	1	1	1	1	930 108 100		Sicherungsscheibe		Safety washer	Rondelle de sécurité	Arandela seguridad
2	65				1	1	1				210 213 102		Kettenradschutz kpl., schwarz		Sprocket guard, black	Protège-pignon, noir	Protector de piñon, negro
2	65	1	1	1							210 213 202		Kettenradschutz kpl., rot		Sprocket guard, red	Protège-pignon, rouge	Protector de piñon, rojo
2	66	1	1	1	1	1	1	1	1	1	923 208 004		6kt-Mutter	M8	Hexagonal nut	Ecrou hexagonal	Tuerca hexagonal

ES-4A, 5A, 6A, 31A, 32A, 36A,
37A, 40A, 41A

DOLMAR

Seite / Page	Pos.	ES-4 A	ES-5 A	ES-6 A	ES-31 A	ES-36 A	ES-40 A	ES-32 A	ES-37 A	ES-41 A	Teil-Nr. Part No. No. de pièce No. de pieza	Hinweise Notes Renseign. Nota	Bezeichnung	Spezifikation Specification	Description	Désignation	Denominación
3	100	=			1						412 030 611		Sternschiene	3/8" .043" 30cm-12"	Sprocket nose bar	Guide à étoile	Barra guía
3	100	=	=			1					412 035 611		Sternschiene	3/8" .043" 35cm-14"	Sprocket nose bar	Guide à étoile	Barra guía
3	100			=			1				412 040 611		Sternschiene	3/8" .043" 40cm-16"	Sprocket nose bar	Guide à étoile	Barra guía
3	101	1			=			1			412 030 211		Sternschiene QuickSet	3/8" .043" 30cm-12"	Sprocket nose bar	Guide à étoile	Barra guía
3	101		1			=			1		412 035 211		Sternschiene QuickSet	3/8" .043" 35cm-14"	Sprocket nose bar	Guide à étoile	Barra guía
3	102	1			1			1			511 290 046		Sägekette	3/8" .043" 30cm-12"	Saw chain	Chaîne	Cadena
3	102		1			1			1		511 290 052		Sägekette	3/8" .043" 35cm-14"	Saw chain	Chaîne	Cadena
3	102			=			1			=	511 290 056		Sägekette	3/8" .043" 40cm-16"	Saw chain	Chaîne	Cadena
3	103	1	1	1	1	1	1	1	1	1	510 090 010		Außenlasche mit Niet	3/8" .043"	Tie strap with rivets	Eclisse extérieure a. rivets	Tira exter. con remache
3	104	1	1	1	1	1	1	1	1	1	510 090 030		Sicherheitslasche	3/8" .043"	Safety tie strap	Eclisse de sécurité	Tira seguridad
3	105	=			=			=			412 030 661	Acc.	Sternschiene	3/8" .050" 30cm-12"	Sprocket nose bar	Guide à étoile	Barra guía
3	105	=	=		=			=			412 035 661	Acc.	Sternschiene	3/8" .050" 35cm-14"	Sprocket nose bar	Guide à étoile	Barra guía
3	105			=				=			412 040 661	Acc.	Sternschiene	3/8" .050" 40cm-16"	Sprocket nose bar	Guide à étoile	Barra guía
3	106	=			=			=			412 030 061	Acc.	Sternschiene QuickSet	3/8" .050" 30cm-12"	Sprocket nose bar	Guide à étoile	Barra guía
3	106		=		=			=			412 035 061	Acc.	Sternschiene QuickSet	3/8" .050" 35cm-14"	Sprocket nose bar	Guide à étoile	Barra guía
3	106			1						1	412 040 061		Sternschiene QuickSet	3/8" .050" 40cm-16"	Sprocket nose bar	Guide à étoile	Barra guía
3	107	=			=			=			528 092 046	Acc.	Sägekette	3/8" .050" 30cm-12"	Saw chain	Chaîne	Cadena
3	107	=	=		=			=			528 092 052	Acc.	Sägekette	3/8" .050" 35cm-14"	Saw chain	Chaîne	Cadena
3	107			1						1	528 092 056		Sägekette	3/8" .050" 40cm-16"	Saw chain	Chaîne	Cadena
3	108	1	1	1	1	1	1	1	1	1	558 092 010		Außenlasche mit Niet	3/8" .050"	Tie strap with rivets	Eclisse extérieure a. rivets	Tira exter. con remache
3	109	1	1	1	1	1	1	1	1	1	558 092 000		Sicherheitslasche	3/8" .050"	Safety tie strap	Eclisse de sécurité	Tira seguridad
3	110	1	1	1	1	1	1	1	1	1	952 100 133		Sägekettenschutz, rot		Chain protection cover, red	Enveloppe protectrice, rouge	Estuche protector, rojo
3	111	1	1	1	1	1	1	1	1	1	941 713 001		Kombischlüssel	SW 13	Universal wrench	Clé combinée	Llave de bujía

ES-4 A, 5 A, 6 A ES-31 A, 32 A ES-36 A, 37 A ES-40 A, 41 A	Inhaltsverzeichnis Index Table des matières Indice	DOLMAR 
---	---	--

1	Gehäuse links, Handschutz, Motor	Case left, hand guard, motor	Carter gauche, protège-main, moteur,	Cárter izqu., protector de mano, motor,
2	Gehäuse rechts, Getriebe, Kettenbremse	Case right, gear, chain brake	Carter droit, engrenage, frein de chaîne	Cárter der., engranaje, freno de cadena
3	Sägeschienen, Sägeketten, Werkzeug	Guide bars, saw chains, tools	Guide-chaîne, chaînes, outils	Rieles guía, cadenas sierra, herramientas

	Zeichenerklärung (D)	Key to symbols (GB)	Légende (F)	Explicación de símbolos (E)
⇒ 1999999 2000000 ⇒ 4/95 ⇒ SI 5/95 Acc. = { m Corr.	Produktion bis Serien-Nr. Neues Teil ab Serien-Nr. Neues Teil ab Monat / Jahr Siehe Technische Information Jahr / Nr. Zubehör (nicht im Lieferumfang) Keine Serienausführung, jedoch verwendbar Beinhaltet Positions-Nr. Meterware Druckfehlerberichtigung	Production to serial number New part from serial number New part from Month / Year See Technical Information Year / No. Accessories (not included in the delivery inventory) No standard execution, may be used Contains item number Sold by the meter Error correction	Production jusqu'à n° de série Nouveau pièce à partir du n° de série Nouveau pièce à partir de mois / année Voir information technique année / n° Accessoires (non compris dans la livraison) Aucune exécut. en série, cependant utilisable contient n° de numéro Au mètre Rectification d'erreurs	Producción hasta N° de serie Pieza nueva a partir de N° de serie Pieza nueva a partir de mes / año Véase inform. técnico año / N° Accesorios (no incluido en la extensión del suministro) No es de serie, pero sirve Contiene pos N° Por metro Fe de erratas
	Verklaring der tekens (NL)	Chiarificazione dei simboli (I)	Objasnitev znakov (SLO)	Επεξήγηση συμβόλων (GR)
⇒ 1999999 2000000 ⇒ 4/95 ⇒ SI 5/95 Acc. = { m Corr.	In productie tot serie-Nr. Nieuw onderdeel vanaf serie-Nr. Nieuw onderdeel vanaf maand / jaar Zie technische informatie jaar / Nr. Accessoires (niet meegeleverd) Geen serieuitvoering, maar wel bruikbaar Omvat Positie-Nr. Metergoed Drukfoutcorrectie	Produzione fino al n. di serie Nuovo pezzo a partire dal n. di serie Nuovo pezzo a partire dal mese / anno Vedere il inform. tecnici del anno / n. Accessori (non compresi nell'insieme di fornitura) Non è un modello di serie, ma ugualm. utilizza. Comprende la posizione n. Articoli a metraggio Rettifica di errori di stampa	Produkcija do serijske številke Novi del od serijske številke dalje Novi del od meseca / leta dalje Glej tehnične informacije od leta / številke. Pritikline (niso v obsegu dostave) Ni serijska izvedba, a uporabno Vsebuje pozicijsko število. Metrsko blago Popravek tiskovnih napak	Παραγωγή μέχρι τον αριθμό σειράς Νέο εξάρτημα από τον αριθμό σειράς Νέο εξάρτημα από το μήνα / έτος Βλέπε πληροφορίες του τεχνικά το έτος / αριθμό Πρόσθετα εξαρτήματα (δεν ανήκουν στη συσκευασία παράδοσης) Δεν έχει εκδοθεί σε σειρά, αλλά χρησιμοποιείται Περιλαμβάνει τον αριθμό θέσης Εμπόρευμα με το μέτρο Διόρθωση λάθους πίεσης